

# **Katalog 2**

**300 - 300 SL**

	Typenkunde	D. B. Vergleich.Nr.	LagerNr
1. Motordichtungssatz	300, b, c, S		2.00001
2. Motordichtungssatz	300d		2.00002
3. Motordichtungssatz	300S		2.00003
4. Motordichtungssatz	300SL		2.00004
5. Motordichtungssatz	300SL Roadster		2.00005
6. Anlaufscheibenhälfte 2,05 mm st.	300c, d, Sc, SL SL Roadster	186 011 01 52	2.01001
7. Zylinderdeckel mit Stützen an Anlasers.	300, b, c, S, SL SL Roadster	186 010 08 10	2.01002
8. Zylinderdeckel mit Stützen an Anlasers.	300d, Sc	199 010 00 10	2.01003
9. Dichtbeilage f. Zyl. d.	alle 300 Modelle	186 015 04 21	2.01004
10. Zyl. deckel an Zünd- kerzenseite	300, b, c, d, S, Sc	186 010 07 10	2.01005
11. Zyl. deckel an Zünd- kerzenseite	300SL, SL Roadster	198 015 01 05	2.01006
12. Dichtbeilage f. Zyl. d.	300, b, c, d, S, Sc	186 015 03 21	2.01007
13. Dichtbeilage f. Zyl. d.	300SL, Roadster	198 015 01 80	2.01008
14. Zylinderkopf	300, S	186 010 11 20	2.01009
15. Zylinderkopf	300b, c	186 010 16 20	2.01010
16. Zylinderkopf	300c	186 010 23 20	2.01011
17. Zylinderkopf	300d	189 010 06 20	2.01012
18. Zylinderkopf	300d	189 010 07 20	2.01013
19. Zylinderkopf mit Nockenwellenlager	300Sc, SL	199 010 06 20	2.01014
20. Zylinderkopf mit Nockenwellenlager	300Sc, SL, SL Roadster	198 010 03 20	2.01015

### Dichtungs- vollsatz. I

Pos.1 Pos.2 Pos.3 Pos.4 Pos.5

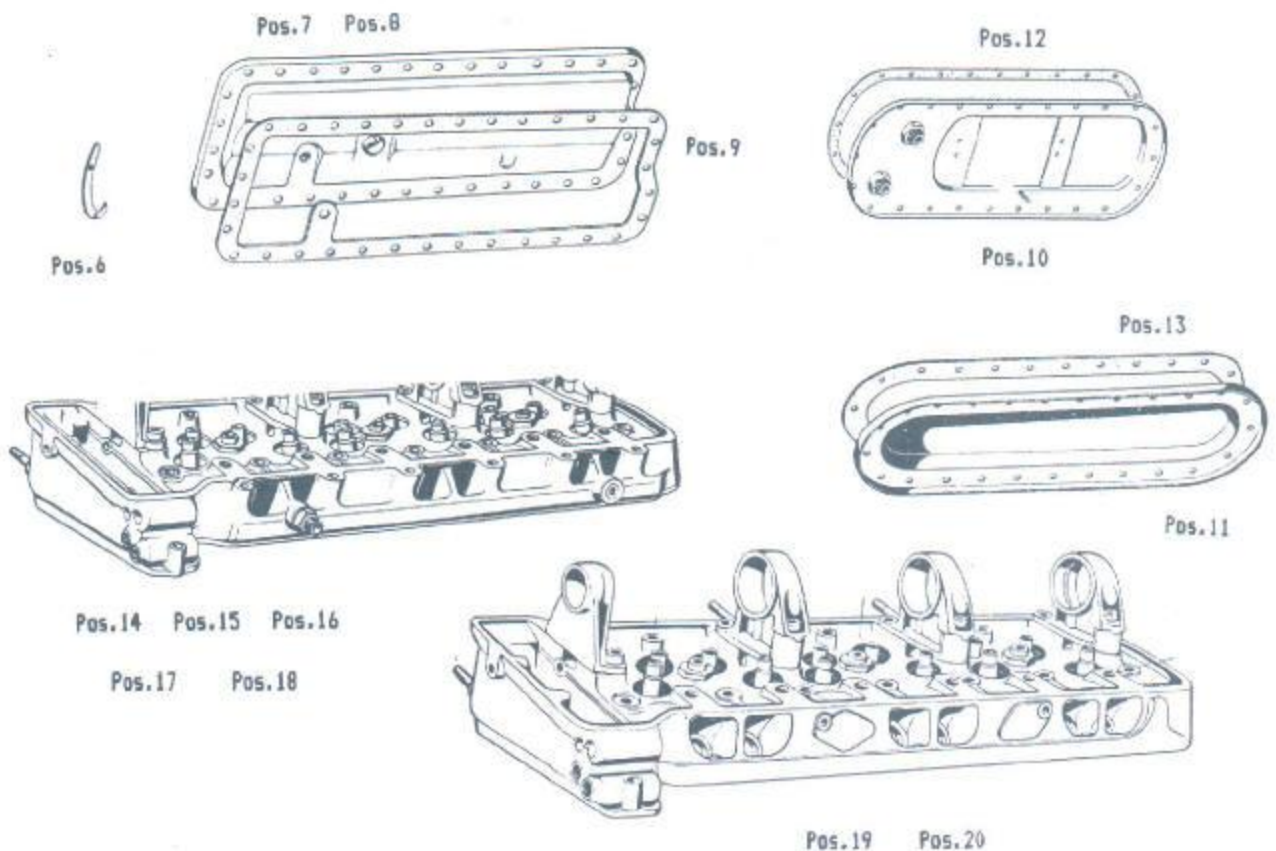

	Typenkunde	D.B. Vergleich.Nr.	LagerNr.
1. Satz Nockenwellenlager normal	300b,c,d,S,Sc,SL	186 050 00 97	2.01016
2. Ventilführung Einlaß	alle 300 Modelle	186 053 03 29	2.01017
3. Ventilführung Einlaß Rep. Stufe 1 d=14,018	300SL Roadster	186 053 06 29	2.01018
4. Ventilführung Einlaß Rep. Stufe 1 d=14,20	300b,c,S,SL Roadster	186 053 04 29	2.01019
5. Ventilführung Einlaß Rep. Stufe 1 d=14,40	300c,SL Roadster	186 053 05 29	2.01020
6. Ventilführung Einlaß Rep. Stufe 1 d=14,40	300SL	198 053 02 29	2.01021
7. Ventilführung Auslaß	300,S	186 053 03 30	2.01022
8. Ventilführung Auslaß	300b,c,d,S,Sc,SL SL Roadster	186 053 04 30	2.01023
9. Ventilführung Auslaß Rep. Stufe 1 d=17,018	300SL Roadster	186 053 09 30	2.01024
10. Ventilführung Auslaß Rep. Stufe 1 d=17,20	300b,c,SSL Roadster	186 053 06 30	2.01025
11. Ventilführung Auslaß Rep. Stufe 1 d=17,40	300c,SL Roadster	186 053 08 30	2.01026
12. Zylinderkopfdichtung	300,c,b,S	186 016 08 20	2.01027
13. Zylinderkopfdichtung	300d	189 016 01 20	2.01028
14. Zylinderkopfdichtung	300Sc,SL,SL Roadster	198 016 02 20	2.01029
15. Zylinderkopfhaube	300,b,c,S	186 010 00 30	2.01030
16. Zylinderkopfhaube	300d	189 010 01 30	2.01031
17. Zylinderkopfhaube	300Sc	199 010 00 30	2.01032
18. Zylinderkopfhaube	300SL,SL Roadster	198 010 00 30	2.01033
19. Schraubdeckel	300,b,c,d,S	136 501 00 54	2.01034



Pos.1



Pos.6

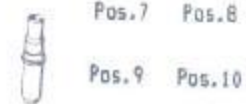

Pos.11

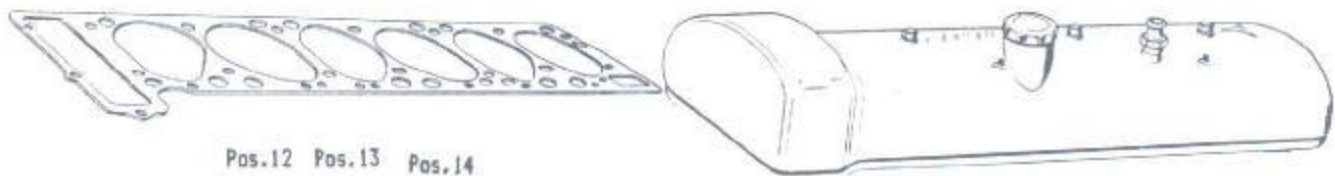

Pos.12 Pos.13 Pos.14

Pos.15 Pos.16

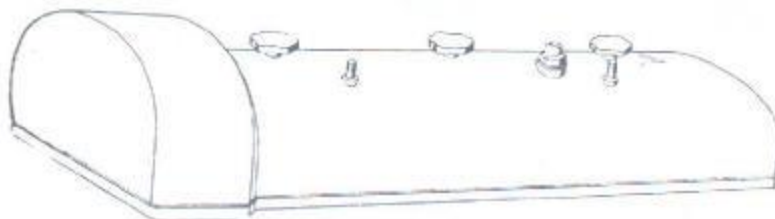

Pos.17 Pos.18

Pos.19



	Typenkunde	D. B. Vergleich.Nr.	LagerNr.
1. Kurbelwelle mit Schwungrad	300, b, c, d, S, Sc	188 030 05 01	2.03001
2. Kurbelw. für Fahrz. mit autom. Getriebe	300c, d	186 030 19 01	2.03002
3. Kurbelwelle	300SL, SL Roadster	198 030 09 01	2.03003
4. Schwungrad m. Zahnkr.	300. b, c, d, S, Sc	186 030 04 05	2.03004
5. Schwungrad	300SL, SL Roadster	198 030 00 05	2.03005
6. Anlaßzahnkranz	alle 300 Modelle	186 032 00 05	2.03006
7. Satz Kurbelw. lagerschalen d=60,0 mm	300, b, c, d, Sc, SL, S SL Roadster	188 030 00 97	2.03007
8. Kurbelw. lagerschalen Rep. st 1 d=59,75 mm	300, b, c, d, Sc, SL, S SL Roadster	188 030 00 97	2.03008
9. Kurbelw. lagerschalen Rep. st 2 d=59,50 mm	300, b, c, d, Sc, SL, S SL Roadster	188 030 00 97	2.03009
10. Kurbelw. lagerschalen Rep. st 3 d=59,25 mm	300, b, c, d, Sc, SL, S SL Roadster	188 030 00 97	2.03010
11. Pleuelstange o. Lager	alle 300 Modelle	186 030 13 20	2.03011
12. Pleuelbuchse 28*24,6*3,2	alle 300 Modelle	186 038 03 50	2.03012
13. Pleuelschraube	alle 300 Modelle	186 038 04 71	2.03013
14. Mutter z. Schraube	alle 300 Modelle	182 038 00 72	2.03014
15. Pleuelbüchse Reparaturstufe (außen d=28,5)	alle 300 Modelle	186 038 04 50	2.03015

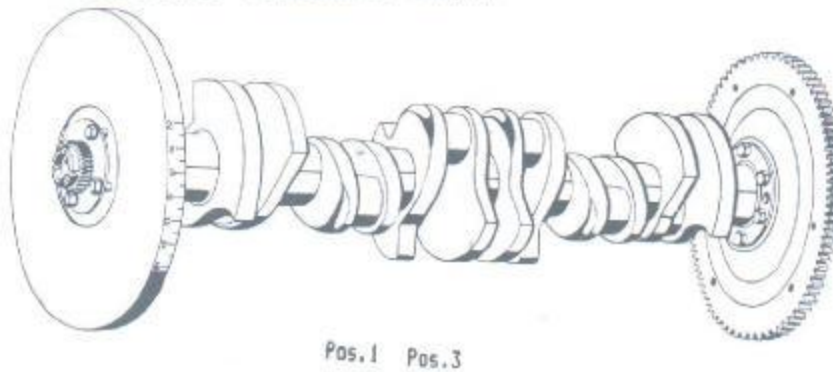

Pos. 1 Pos. 3

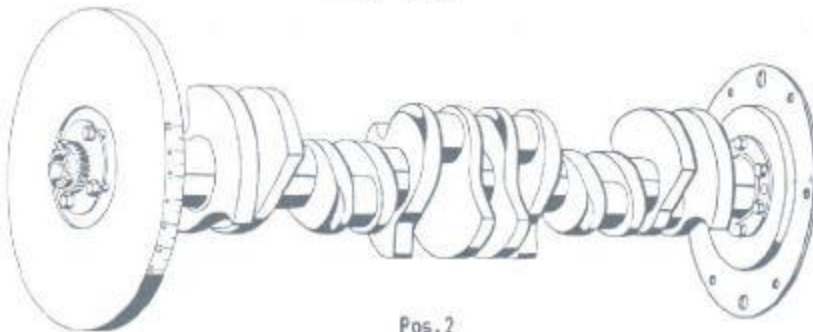

Pos. 2

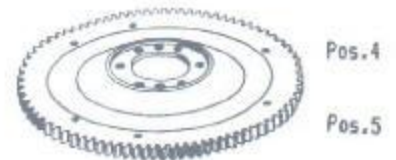

Pos. 4

Pos. 5



Pos. 6



Pos. 7 Pos. 8 Pos. 9 Pos. 10



Pos. 11



Pos. 12



Pos. 15



Pos. 14



Pos. 13

	Typenkunde	D. B. Vergleich.Nr.	LagerNr.
1. Satz Pleulagerschalen	300b, c, d, Sc, SL, S d=52 mm Std. SL Roadster		2.03016
2. Satz Pleulagerschalen	300b, c, d, Sc, SL, S d=51,75 mm 1 Rep.stufe SL Roadster		2.03017
3. Satz Pleulagerschalen	300b, c, d, Sc, SL, S d=51,5 mm 2 Rep.stufe SL Roadster		2.03018
4. Satz Pleulagerschalen	300b, c, d, Sc, SL, S d=51,25 mm 3 Rep.stufe SL Roadster		2.03019
5. Kolben komplett Std.	300b, c	186 030 19 17	2.03020
6. Kolben komplett	300b, c	186 030 21 17	2.03021
1 Rep. St. d=85,5mm			
7. Kolben komplett	300b, c	186 030 22 17	2.03022
2 Rep. St. d=86,0mm			
8. Kolben komplett	300b, c	186 030 23 17	2.03023
3 Rep. St. d=86,5mm			
9. Kolben komplett Std.	300Sc, SL Roadster	198 030 10 17	2.03024
10. Kolben komplett	300Sc, SL Roadster	198 030 12 17	2.03025
1 Rep. St. d=85,5mm			
11. Kolben komplett	300Sc, SL Roadster	198 030 13 17	2.03026
2 Rep. St. d=86,0mm			
12. Kolben komplett	300Sc, SL Roadster	198 030 14 17	2.03027
3 Rep. St. d=86,5mm			
13. Nockenwelle	300, c, SL	186 050 07 01	2.05001
14. Nockenwelle	300b, c, d, Sc	186 050 08 01	2.05002
15. Nockenwelle	300S	188 050 02 01	2.05003
16. Nockenwelle	300SL, SL Roadster	198 050 00 01	2.05004
17. Schwingungsdämpfer mit Nockenwellenr.	alle 300 Modelle	180 050 01 82	2.05005
18. Nockenwellenrad	alle 300 Modelle	180 052 01 01	2.05006



Pos.1 Pos.2 Pos.3 Pos.4



Pos.5 Pos.6 Pos.7 Pos.8



Pos.9 Pos.10

Pos.11 Pos.12



Pos.13 Pos.14



Pos.17



Pos.18



Pos.15 Pos.16



	Typenkunde	D. B.	Vergleich.Nr.	LagerNr.
1. Zwischenradwelle mit Anlaufring	300b,c,S,Sc,SL SL Roadster	186	050 07 06	2.05007
2. Zwischenrad 30 Zähne	300c,SL,SL Roadster	180	052 03 02	2.05008
3. Zwischenrad	300d,Sc	199	052 01 02	2.05009
4. Zweifachrollenkette m. Schloß f. St.antrieb	alle 300 Modelle	186	052 03 10	2.05010
5. Gleitschiene	alle 300 Modelle	180	050 08 16	2.05011
6. Kettenspanner	300,b,c,d,S,Sc	186	050 08 11	2.05012
7. Spannrad m. Buchse	alle 300 Modelle	180	050 01 09	2.05013
8. Einlaßventil	300,b,c,S	186	053 02 01	2.05014
9. Einlaßventil	300d,Sc,SL Roadster	189	053 00 01	2.05015
10. Auslaßventil	300,b,c,S	186	053 05 05	2.05016
11. Auslaßventil	300d,Sc,SL Roadster	189	053 02 05	2.05017
12. Äußere Ventildfeder f. Ein-u. Auslaßventil	alle 300 Modelle	186	053 01 20	2.05018
13. Innere Ventildfeder f. Ein-u. Auslaßventil	alle 300 Modelle	186	053 01 22	2.05019
14. Ventildfederteller f. Auslaßventil	alle 300 Modelle	186	050 00 23	2.05020
15. Ventildfederteller f. Einlaßventil	alle 300 Modelle	186	053 03 25	2.05021
16. Schwinghebel m. Buchse für Einlaßventil	alle 300 Modelle	186	050 03 33	2.05022
17. Schwinghebel m. Buchse für Auslaßventil	alle 300 Modelle	186	050 03 34	2.05023
18. Schwinghebelachse	300,b,c,S,Sc,SL	186	055 04 05	2.05024
19. Schwinghebelachse	300d,SL Roadster	186	055 06 05	2.05025
20. Fallstromvergaser vorn und hinten	300	000	071 17 01	2.07001

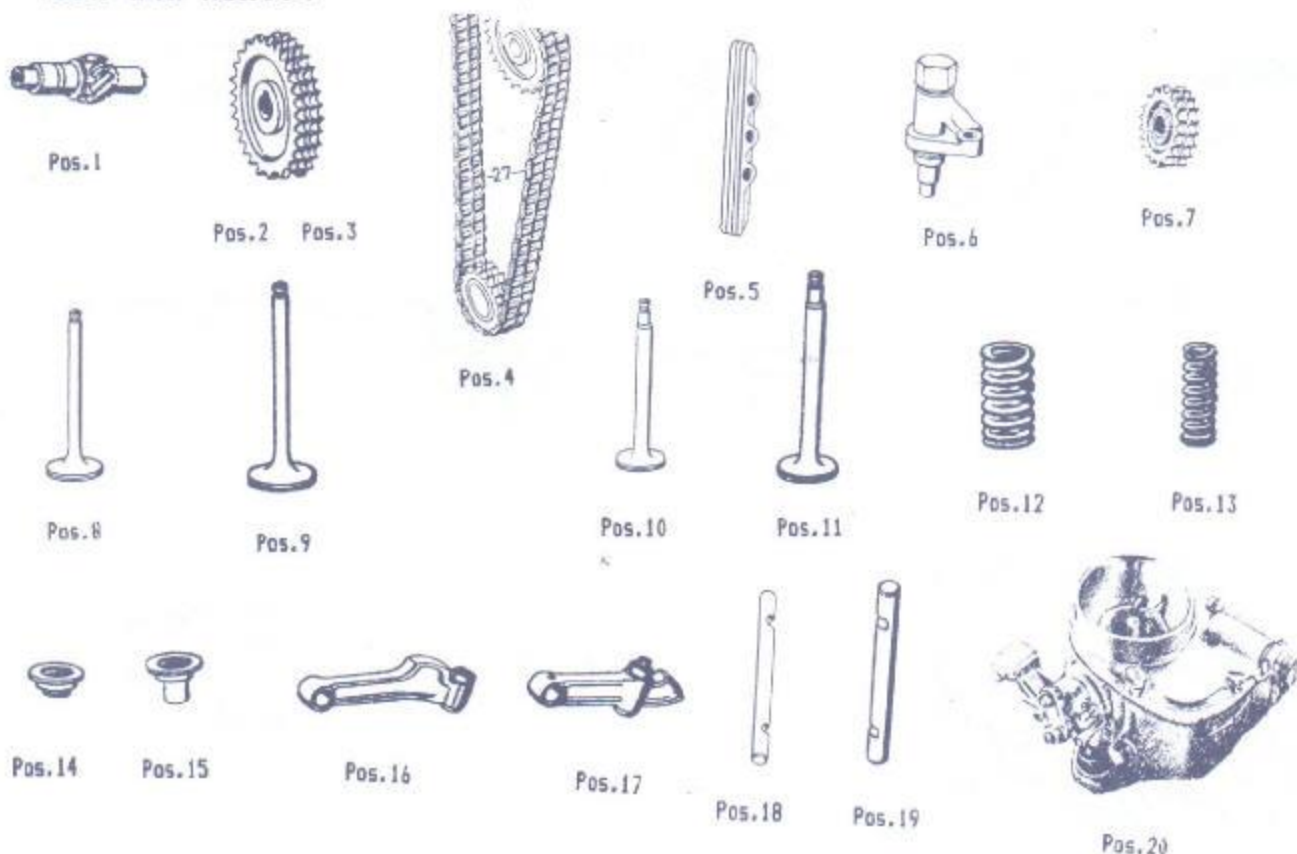

	Typenkunde	D. B. Vergleich.Nr.	LagerNr.
1. Kraftstoffleitung Vergaser	300	186 070 03 32	2.07002
2. Solex Register Vergaser 32	300b	000 071 33 01	2.07003
3. Kraftstoffleitung	300b	186 070 05 32	2.07004
4. Vergaser 32 PAIAT	300c	000 071 67 01	2.07005
5. Kraftstoffleitung Vergaser	300c	186 070 08 32	2.07006
6. Fallstromvergaser vorn komplett	300S	188 070 00 04	2.07007
7. Fallstromvergaser mitten komplett	300S	188 070 02 04	2.07008
8. Fallstromvergaser hinten komplett	300S	188 070 01 04	2.07009
9. Kraftstoffleitung von d.Kr.st. Förderrep. z.Verg.	300S	188 070 00 32	2.07010
10. Einspritzpumpe mit Regler u. Förderpumpe	300d	002 074 16 01	2.07011
11. Einspritzpumpe mit Regler u. Förderpumpe	300SC	001 074 67 01	2.07012
12. Kraftst.-Förderpumpe	300Sc, d	000 091 55 01	2.07013
13. Einspritzventil im Saugrohr	300d	000 078 00 22	2.08001
14. Einspritzdüse im Zylinder Kurbelgehäuse	300Sc	000 017 20 12	2.08002
15. Klappenstutzen	300d	000 140 06 53	2.08003
16. Klappenstutzen	300WSc	000 140 00 53	2.08004

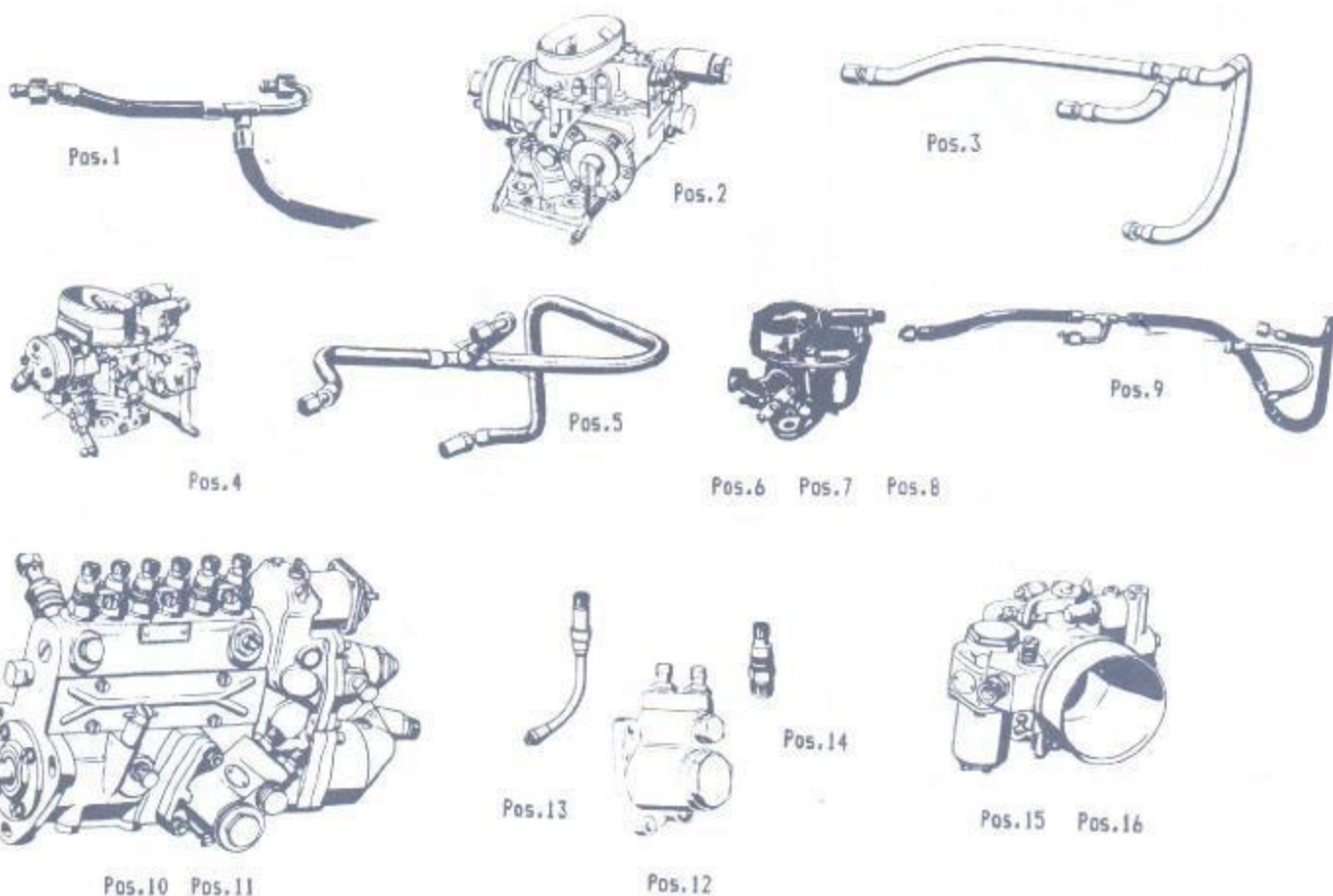



	Typenkunde	D. B.	Vergleich.Nr.	LagerNr.
1. Einspritzpumpe mit Membranregler u. K. st. pumpe	300SL	000	074 65 02	2.08005
2. Einspritzpumpe mit Membranregler u. K. st. pumpe	300SL Roadster	001	074 55 01	2.08006
3. Einspritzdüse im Zylinder Kurbelgehäuse	300SL, Roadster	000	017 20 12	2.08007
4. Klappenstutzen	300 SL	000	140 02 53	2.08008
5. Klappenstutzen	300 SL Roadster	000	140 03 53	2.08009
6. Kraftstoffpumpe	300, c, b,	000	091 54 01	2.09001
7. Saugerräuschkämpfer	300	000	094 21 02	2.09002
8. Saugerräuschkämpfer	300b, c	000	094 58 02	2.09003
9. Saugerräuschkämpfer	300S	000	094 29 02	2.09004
10. Oelbad Luftfilter	300d	001	094 94 02	2.09005
11. Oelbad Luftfilter	300Sc	000	094 97 02	2.09006
12. Einsatz	300d, Sc	000	094 35 04	2.09007
13. Pico Filterpatrone	300d	000	094 52 04	2.09008
14. Dämpferfilter	300SL, SL Roadster	000	094 74 02	2.09009
15. Kraftstofffilte	300d, Sc	000	477 63 01	2.09010
16. Filtereinsatz	300d, Sc	000	477 43 15	2.09011
17. Saugrohr	300	186	140 03 01	2.14001
18. Saugrohr	300b	186	140 09 01	2.14002
19. Saugrohr	300c	186	140 10 01	2.14003
20. Saugrohr	300d	189	140 00 01	2.14004

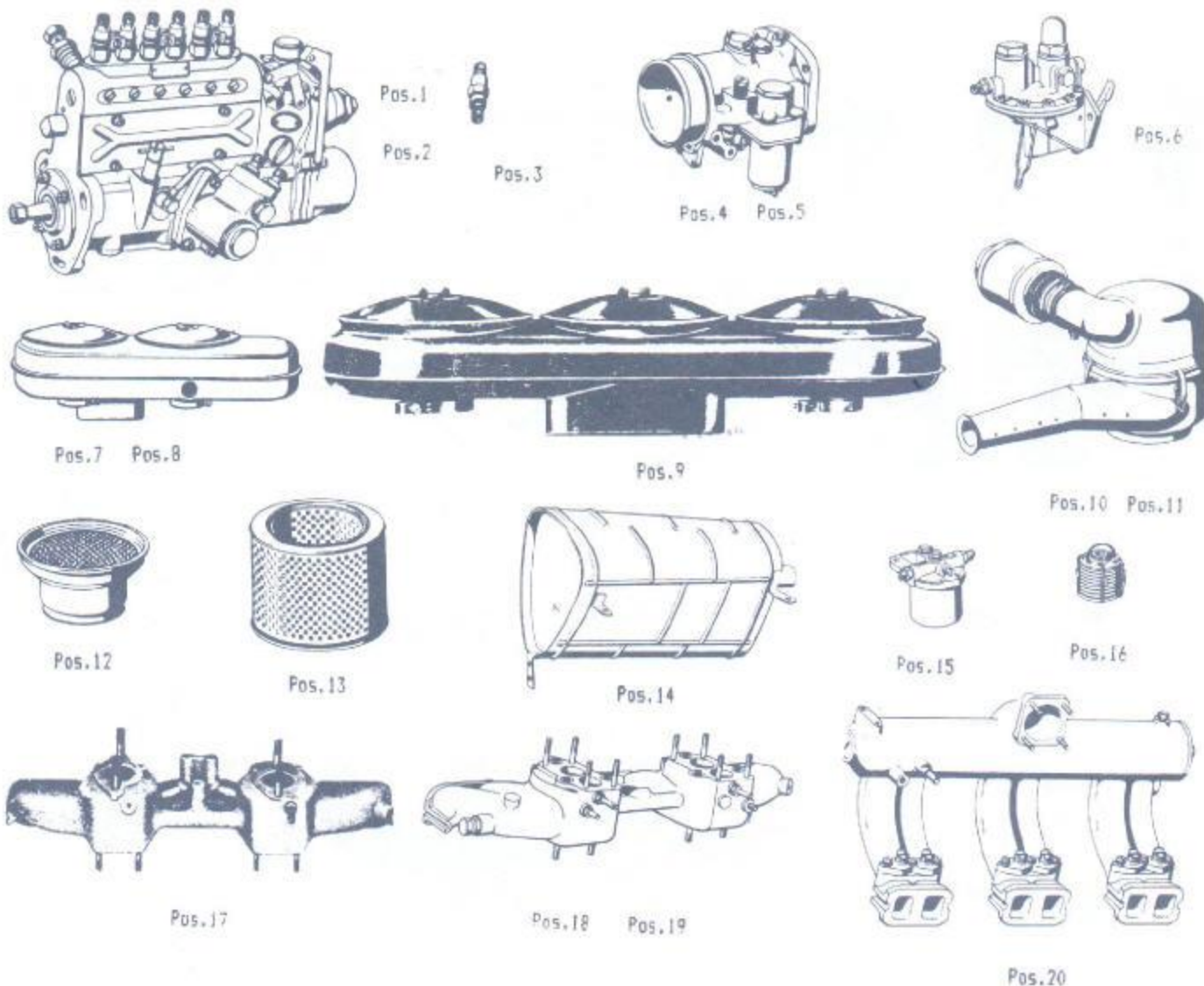



	Typenkunde	D.B. Vergleich.Nr.	LagerNr.
1. Saugrohr am vorderen Vergaser f. Zylinder 1 u. 2	300S	188 140 02 03	2.14005
2. Saugrohr am mittleren Vergaser f. Zylinder 3 u. 4	300S	188 140 01 03	2.14006
3. Saugrohr am mittleren Vergaser f. Zylinder 5 u. 6	300S	188 140 00 03	2.14007
4. Saugrohr	300SC	199 140 01 01	2.14008
5. Saugrohr	300 SL	198 140 00 01	2.14009
6. Saugrohr	300 SL Roadster	198 140 01 01	2.14010
7. Auspuffkr. vo. kompl.	300	186 140 09 11	2.14011
8. Auspuffkr. hi. kompl.	300	186 140 10 11	2.14012
9. Auspuffkr. vo. kompl.	300b,c	186 140 14 11	2.14013
10. Auspuffkr. hi. kompl.	300b,c	186 140116 11	2.14014
11. Auspuffkr. vo. Teil	300d,Sc	186 142 00 02	2.14015
12. Auspuffkr. hi. Teil	300d,Sc	186 142 00 04	2.14016
13. Auspuffkr. vo. Teil	300S	188 142 00 02	2.14017
14. Auspuffkr. hi. Teil	300S	188 142 00 04	2.14018
15. Auspuffkr. vorn	300 SL	198 140 00 14	2.14019
16. Auspuffkr. vorn	300 SL Roadster	198 140 02 14	2.14020
17. Auspuffkr. hinten	300 SL, SL Roadster	198 140 01 14	2.14021
18. Anlasser	300,b,c,S,Sc	000 151 35 01	2.15001
19. Anlasser	300c,SL,SL Roadster	000 151 02 01	2.15002
20. Anlasser	300d	000 151 89 01	2.15003

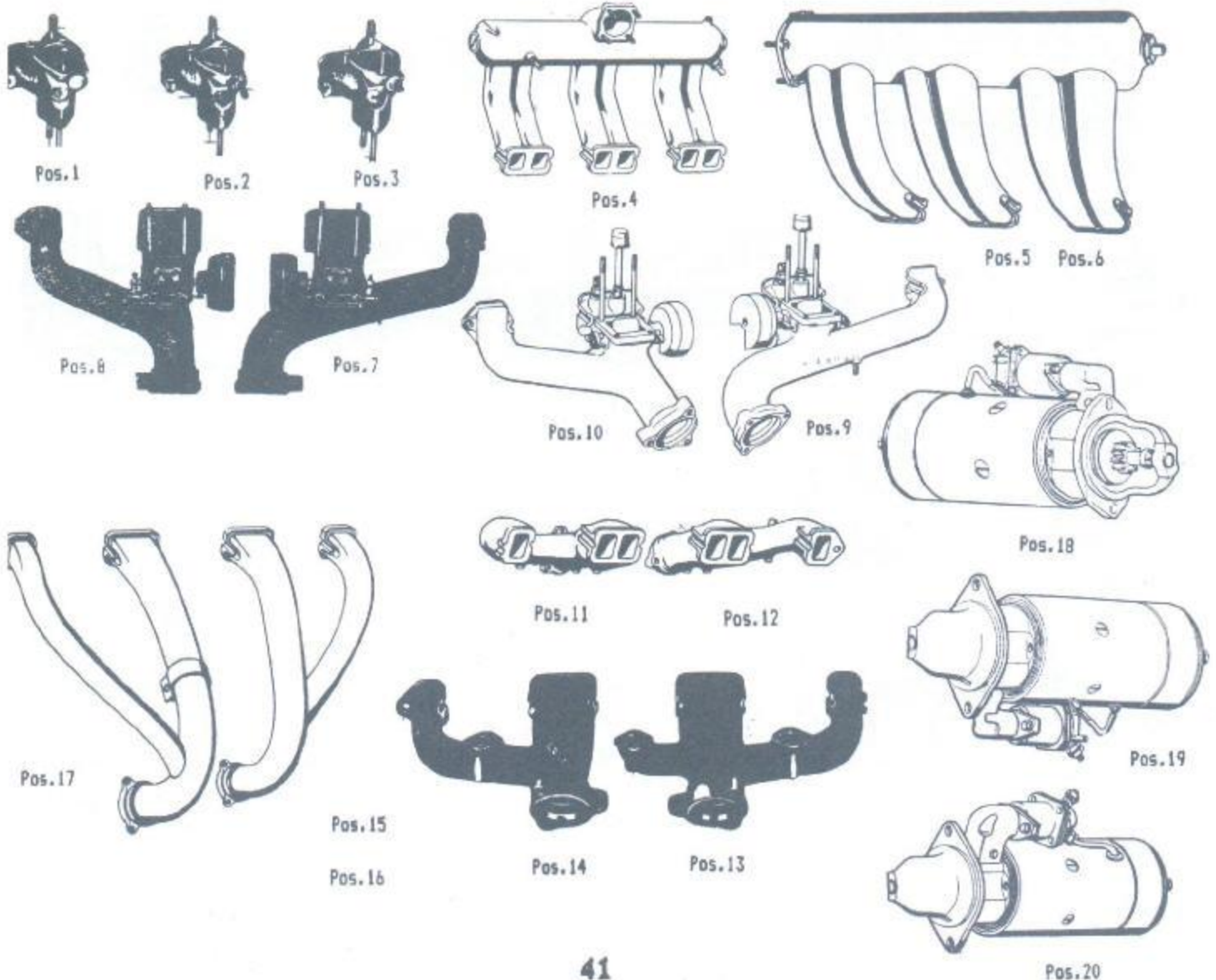

	Typenkunde	D. B.	Vergleich.Nr.	LagerNr.
1. Lichtmaschine	300, b, c, S, SL, SL Roadster	000	154 75 01	2.15004
2. Lichtmaschine	300d, SC	000	154 44 02	2.15005
3. Kupplungshälfte innen 27 Zähne auf d. Lichtm.	300, b, c, d, S, Sc, SL SL Roadster	186	155 03 09	2.15006
4. Mitnehmerring innen 18 Zähne, außen 27 Zähne	300, b, c, d, S, Sc, SL SL Roadster	186	155 00 10	2.15007
5. Zündverteiler mit Kupplung	300, c, S, b	186	150 00 13	2.15008
6. Zündverteiler mit Kupplung	300c	186	150 03 13	2.15009
7. Zündverteiler m. zwei- teiliger Kupplung	300d	000	158 69 01	2.15010
8. Zündverteiler m. ein- teiliger Kupplung	300d, Sc	199	158 00 01	2.15011
9. Zündverteiler mit Kupplung	300SL	198	150 00 13	2.15012
10. Zündverteiler	300 SL Roadster	000	158 67 01	2.15013
11. Verteilerscheibe mit Schleifkohle	300, b, c, d, S, Sc, Sl	000	158 05 02	2.15014
12. Verteilerscheibe	300 SL Roadster	000	158 11 02	2.15015
13. Unterbrecherhebel	300, S, b, c, Sc, Sl, d	000	158 02 30	2.15016
14. Kontaktträger mit Kontakt	300b, c, Sc, Sl, d	000	158 04 32	2.15017
15. Kontaktsatz	300 SL, Roadster	000	158 10 90	2.15018

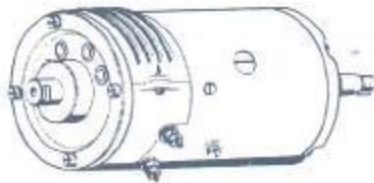

Pos. 2



Pos. 3



Pos. 4



Pos. 5

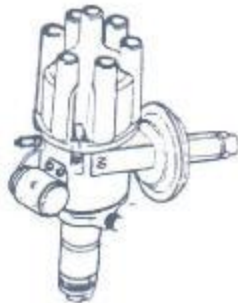

Pos. 6



Pos. 7 Pos. 8



Pos. 9

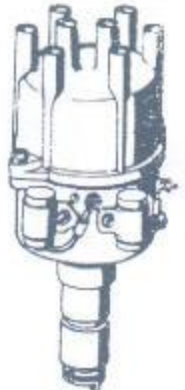

Pos. 10



Pos. 11



Pos. 12



Pos. 13



Pos. 14



Pos. 15



	Typenkunde	D. B.	Vergleich.Nr.	LagerNr.
1. Verteilerlaufstück	300,c,S	000	158 03 31	2.15019
2. Zündverteiler entst.	300b,c,d,Sc,SL	000	158 08 31	2.15020
3. Zündkabelsatz	300Sc,SL	198	150 00 19	2.15021
4. Zündleitungssatz mit Schutzrohr f. Zweikreiszünd.	300 SL Roadster	198	150 02 19	2.15022
5. Oelpumpe	300c,b,S	186	180 06 01	2.18001
6. Oelpumpe	300d	189	180 00 01	2.18002
7. Oelpumpe vollständig	300Sc	199	180 00 01	2.18003
8. Oelpumpe	300SL	194	180 00 01	2.18004
9. Oelabsaugpumpe	300 SL Roadster	198	180 01 01	2.18005
10. Oeldruckpumpe	300 SL Roadster	198	180 02 01	2.18006
11. Spule für Einsatz	300b,c,S,SL,SL Roadster	000	184 04 12	2.18007
12. Filtereinsatz	300Sc,d	000	184 22 25	2.18008
13. Oelkühler f. Getriebe	300c,d	000	188 10 01	2.18009
14. Wasserpumpe	300d,Sc,b,c,SL,SL Road.	199	200 00 01	2.20001
15. Gummilager vorn	300,b,c,d,S,Sc	301	220 01 17	2.22001
16. Gummilager vorn (Lichtmaschinen- seite)	300SL,SL Roadster	198	240 00 17	2.22002
17. Gummilager vorn (Zündkerzenseite)	300SL,SL Roadster	198	240 01 17	2.22003
18. Gummilager hinten	300,b,S,SL,SL Roadster	181	220 00 17	2.22004
19. Gummilager hinten	300c,d	186	240 03 18	2.22005
20. Gummilager hinten	300c,D,Sc	186	240 02 18	2.22006

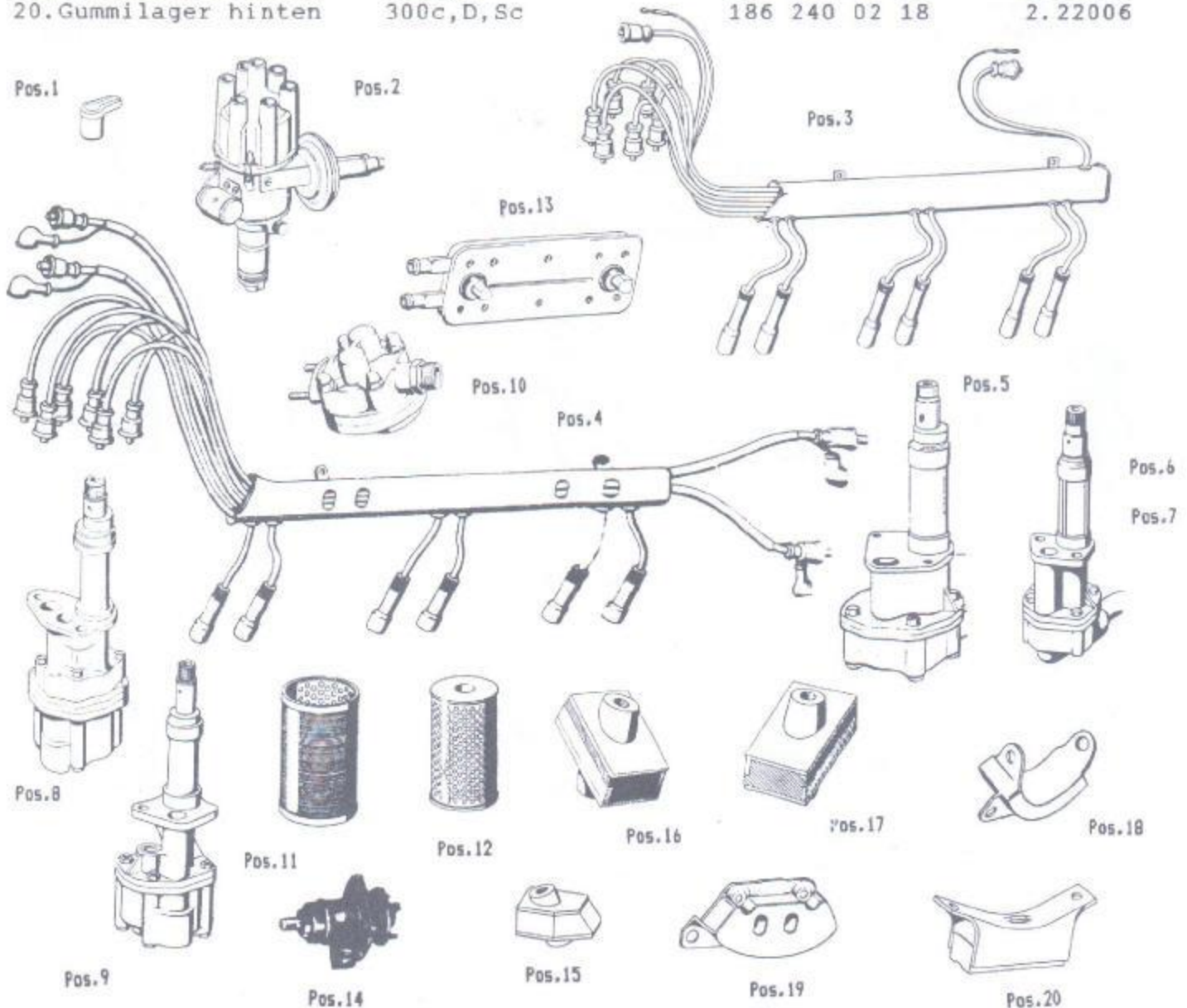

	Typenkunde	D.B.	Vergleich.Nr.	LagerNr.
1. Kupplung mit Blattfeder aufh. ohne Mitnehmersch.	300Sc,c,b,S,d	188	250 02 04	2.25001
2. Kupplung H 18 ST.9	300 SL,SL Roadster	198	250 00 04	2.25002
3. Mitnehmerscheibe	300,b,c,d,S,Sc	186	250 05 03	2.25003
4. Kupplungscheibe	300 SL,SL Roadster	198	250 02 03	2.25004
5. Ausrückkörper m. Lager	300b,c,d,Sc	186	250 11 15	2.25005
6. Ausrückkörper	300 SL,SL Roadster	198	250 01 15	2.25006
7. Ausrücklager	300 SL,SL Roadster	198	254 01 10	2.25007
8. Verbindungsschlauch	300,b,c,d,S,Sc	186	570 01 36	2.25008
9. Manschette f. Ausr.gab.	300c,d,Sc	120	254 00 97	2.25009
10. Vorderfeder	300S	188	321 00 04	2.32001
11. Vorderfeder Draht	300,c,d,b	186	321 17 04	2.32002
12. Vorderfeder	300 Sc	188	321 02 04	2.32003
13. Vorderfeder	300 SL	198	321 03 04	2.32004
14. Vorderfeder Draht	300 SL Roadster	198	321 12 04	2.32005
15. Gummilager für Drehstab d=22	300,b,c,d,S,Sc	186	323 01 85	2.32006
16. Gummilager für Drehstab an Rahmen	300 SL	121	323 00 85	2.32007
17. Gummilager für Drehstab an Rahmen	300 SL Roadster	198	323 00 85	2.32008
18. Rep.satz Drehstab	alle 300 Modelle			2.32009
19. Gummipuffer	alle 300 Modelle	186	333 00 65	2.32026
20. Stoßdämpfer vorn	300,c,Sc,b,d	000	323 55 00	2.32010
21. Stoßdämpfer vorn	300 SL Roadster	000	323 49 00	2.32011

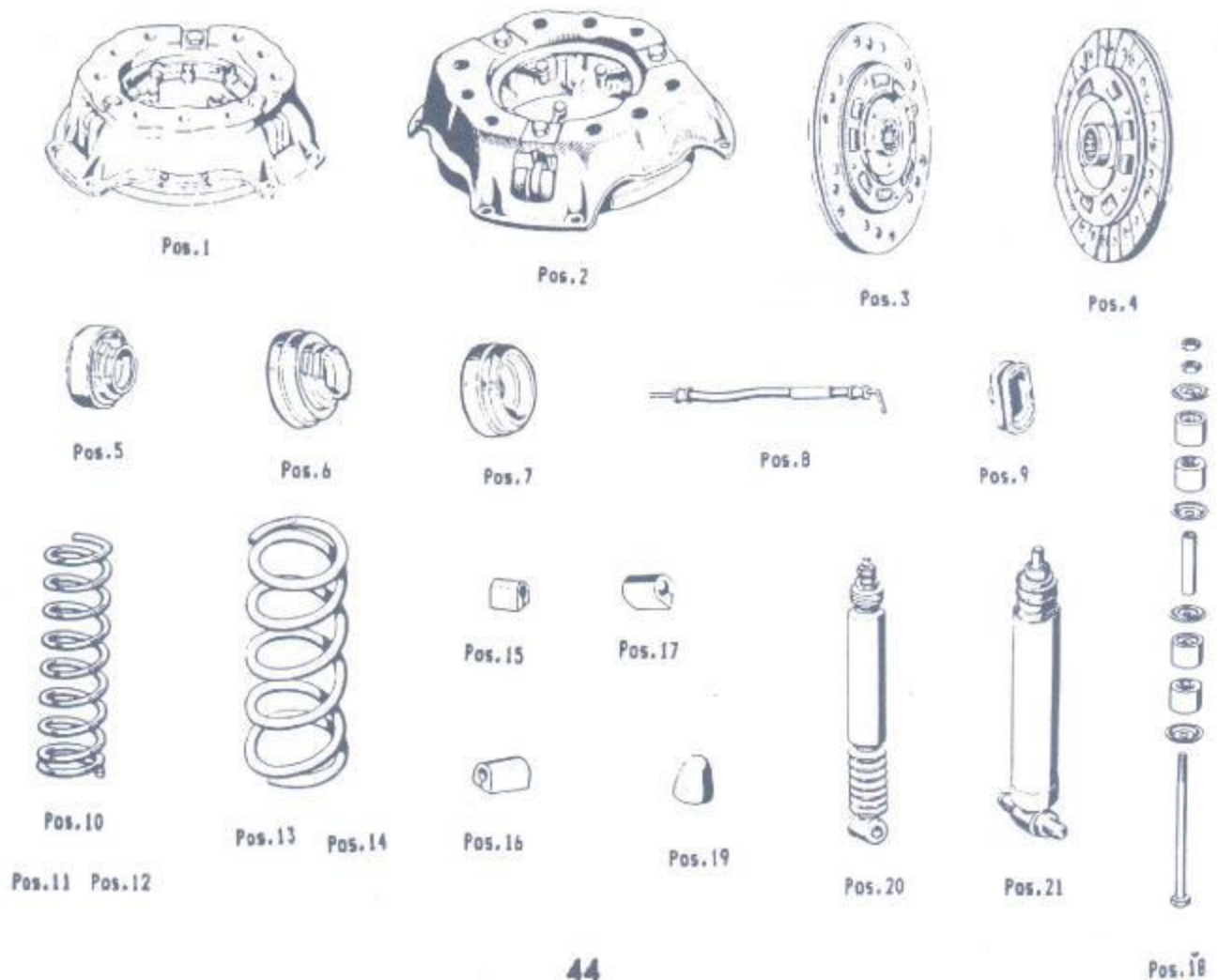



	Typenkunde	D. B.	Vergleich.Nr.	LagerNr.
1. Hinterfeder	300,b	186	324 13 04	2.32012
2. Hinterferder Draht	300c,d	186	324 21 04	2.32013
3. Hinterfeder Export	300c,d	186	324 14 04	2.32014
4. Hinterfeder	300S	188	324 02 04	2.32015
5. Hinterfeder	300Sc	188	324 04 04	2.32016
6. Hinterfeder	300SL	198	324 01 04	2.32017
7. Hinterferder Draht	300 SL Roadster	198	324 10 04	2.32018
8. Halter f. Gummipuffer	300,b,c,d,S,Sc,SL	153	325 00 43	2.32019
9. Gummipuffer unten	300,b,c,d,S,Sc	183	325 00 44	2.32020
10. Stoßdämpfer hinten	300,c,b,d,Sc	000	326 49 00	2.32021
11. Stoßdämpfer hinten	300 SL Roadster	000	326 59 00	2.32022
12. Gummipuffer f. Fangb.	300,b,c,d,S,Sc,Sl	153	325 01 44	2.32023
13. Spannvorrichtung für hintere Drehstabfederung	300,b	186	320 02 12	2.32024
14. Spannvorrichtung	300c,d	186	320 03 12	2.32025
15. Büchse im Achs- schenkel unten	300,b,c,d,S,Sc	186	332 00 49	2.33001
16. Büchse im Achs- schenkel oben	300,b,c,d,S,Sc	186	332 00 48	2.33002
17. Büchse	300 SL,SL Roadster	198	332 01 48	2.33003
18. Achsschenkelbolzen	300,b,c,d,S,Sc	186	330 01 19	2.33004
19. Achsschenkelträger am Querlenker unten	300,b,c,d,S,Sc	186	333 04 09	2.33005
20. Achsschenkelträger für Querlenker unten	300 SL,SL Roadster	198	333 00 09	2.33006
21. Achsschenkeltr. ob.	alle 300 Modelle	186	333 03 09	2.33007

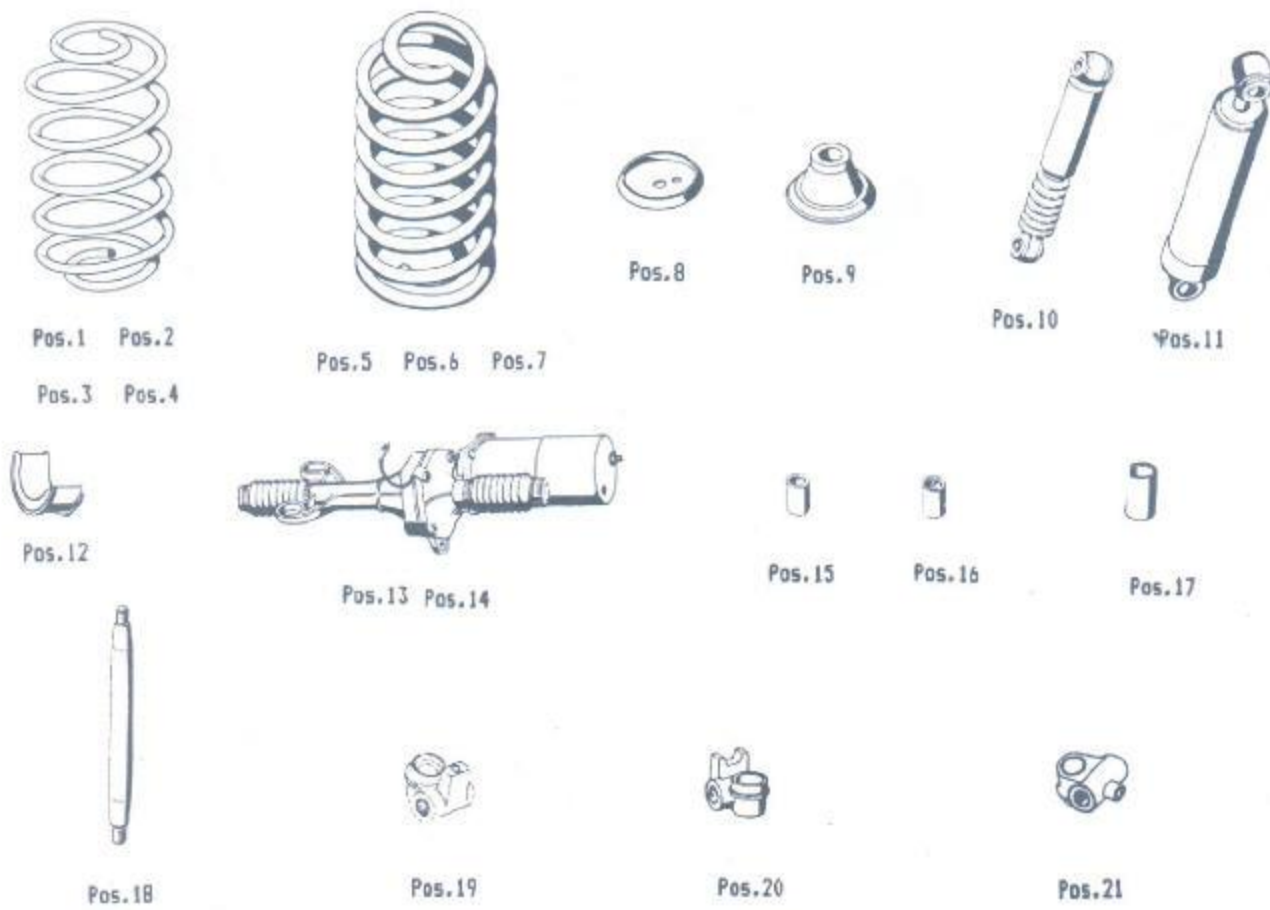

	Typenkunde	D.B.	Vergleich.Nr.	LagerNr.
1. Spurstangenkopf 18mm Links-Gewinde	300,b,c,d,S,Sc	183	330 00 48	2.33008
2. Spurstangenkopf 18mm Rechts-Gewinde	300,b,c,d,S,Sc	183	330 01 48	2.33009
3. Kugelpfannenkopf innen Rechtsgewinde (li.u.re)	300 SL,SL Roadster	198	330 00 48	2.33010
4. Kugelpfannenk. li. außen	300 SL,SL Roadster	198	330 01 48	2.33011
5. Kugelpfannenk. re. außen	300 SL,SL Roadster	198	330 02 48	2.33012
6. Dichtring für Quer- lenker innen	alle 300 Modelle	181	333 00 80	2.33013
7. Gewindebüchse f. Quer- lenker	alle 300 Modelle	181	333 01 48	2.33014
8. Gewindebüchse f. Quer- bolzen an Lagerkö.	alle 300 Modelle	181	333 02 48	2.33015
9. Abstandrohr f. Ab- stützung Vorderachse Lagerk.	300,b,c,,S,Sc	181	333 01 53	2.33016
10. Teller f. Gummipuffer	300,b,c,S,Sc	181	333 00 67	2.33017
11. Gummipuffer	300,b,c,S,Sc	181	333 03 65	2.33018
12. Gewindeb. f. Querl. u.	alle 300 Modelle	181	333 01 74	2.33019
13. Dichtring f. Querl. a.	alle 300 Modelle	181	333 01 80	2.33020
14. Lagerbü. f. Trag- bolzen unten	300,b,c,d,S,Sc	186	333 14 12	2.33021
15. Lagerbü. f. Trag- bolzen oben	300,b,c,d,S,Sc	181	333 01 12	2.33022
16. Lagerebüchse außen d=50,0mm	300SL,SL Roadster	198	333 01 12	2.33023
17. Lagerebüchse außen d=50,3mm	300SL,SL Roadster	198	333 02 12	2.33024



Pos.1



Pos.2



Pos.3



Pos.4



Pos.5



Pos.6



Pos.7



Pos.8



Pos.9



Pos.10



Pos.11



Pos.12



Pos.13



Pos.14



Pos.15

Pos.16

Pos.17



	Typenkunde	D. B.	Vergleich.Nr.	LagerNr.
1. Dichtring für Querlenker innen	alle 300 Modelle	181	333 00 80	2.33025
2. Gewindebüchse für Querlenker oben m. Sechskant	alle 300 Modelle	181	333 01 48	2.33026
3. Gewindebüchse für Querlenker oben	alle 300 Modelle	181	333 02 48	2.33027
4. Gummipuffer f. Federt.	alle 300 Modelle	181	333 01 65	2.33028
5. Dichtring f. Querl. a.	alle 300 Modelle	181	333 01 80	2.33029
6. Gewindebüchse	300,S	181	333 00 48	2.33030
7. Gewindebolzen f. Querlenker oben a. Achssch.	300b,c,d,S,Sc,SL SL Roadster	184	333 04 30	2.33031
8. Gummimanschette 52 mm	300,b,S,SL	136	351 01 91	2.35001
9. Gummimansch. geteilt	300,S	136	350 01 37	2.35002
10. Gummimanschette	300c,d,Sc,SL Roadster	188	357 00 91	2.35003
11. Hinterachsmanschette	300 SL	136	351 02 91	2.35004
12. Gummiring f. Hinterachsaufhängung vorn	300,b,S,SL	181	351 01 44	2.35005
13. Gummiring f. Hinterachsaufhängung hinten	300,b,S,SL	181	351 00 44	2.35006
14. Gummilager f. Fahrzeuge m. syn. 4 Gang Getr.	300c,d,Sc	188	351 01 48	2.35007
15. Gummilager f. Hinterachsgehäuse	300 SL Roadster	198	351 01 48	2.35008
16. Gummilager f. Schubstrebe an Lagerb. Tragrohr	300c,d,Sc,SL Roadster	188	352 00 65	2.35009
17. Gummilager f. Schubstrebe vorn	300c,d,Sc,SL Roadster	000	352 01 65	2.35010



Pos. 1



Pos. 2



Pos. 3



Pos. 4



Pos. 5



Pos. 6



Pos. 7



Pos. 8



Pos. 9



Pos. 10



Pos. 11



Pos. 12



Pos. 13



Pos. 14



Pos. 16



Pos. 17

Pos. 15

	Typenkunde	D. B.	Vergleich.Nr.	LagerNr.
1. Raddeckel verchromt	300, S, Sc, SL, SL Roadster	186	401 00 25	2.40001
2. Felgenzierring verch.	300, S	186	401 00 23	2.40002
3. Zierblende	300b, c, d	186	400 00 25	2.40003
4. Gummilager f. Gelenkwelle Zwischenlager	300, b, S	186	410 04 81	2.41001
5. Bremsbacke mit Belag f. Vorderr. li. u. re	300b, d	186	420 34 20	2.42001
6. Bremsbacke mit Belag	300c, Sc, SL, SL Road.	198	420 01 20	2.42002
7. Bremsbacke mit Belag	300d, SL Road.	198	420 22 20	2.42003
8. Bremsbacke mit Belag	300S	188	420 04 20	2.42004
9. Bremsbelag	300b, c, d, S, Sc	188	421 01 10	2.42005
10. Radbremszylinder für Vorderr. br. li.	300	000	420 26 18	2.42006
11. Radbremszylinder für Vorderr. br. re.	300	000	420 27 18	2.42007
12. Radbremszylinder für Vorderr. br. li.	300b, c, d, S, Sc, SL SL Roadster	000	420 38 18	2.42008
13. Radbremszylinder für Vorderr. br. re.	300b, c, d, S, Sc, SL SL Roadster	000	420 39 18	2.42009
14. Radzylinder 31,75 mm	300d, SL Roadster	001	420 23 18	2.42010
15. Bremszange links	300 SL Roadster	000	421 02 98	2.42011
16. Bremszange rechts	300 SL Roadster	000	421 03 98	2.42012
17. Radzylinder 57,15 mm	300 SL Roadster	001	420 63 18	2.42013



Pos. 1



Pos. 2



Pos. 3



Pos. 4

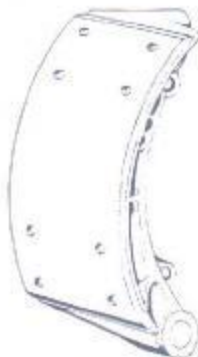

Pos. 5



Pos. 6



Pos. 7



Pos. 8

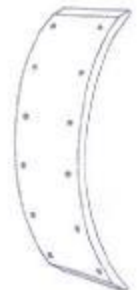

Pos. 9



Pos. 10



Pos. 11



Pos. 14



Pos. 12



Pos. 13



Pos. 17



Pos. 15



Pos. 16



	Typenkunde	D. B.	Vergleich.Nr.	LagerNr.
1. Bremsbacke mit Belag f. Hinterrad vorn	300	186 420 27 20		2.42014
2. Bremsbacke mit Belag f. Hinterrad hinten	300	186 420 28 20		2.42015
3. Bremsbacke mit Belag f. Hinterrad vorn	300b,d	186 420 40 20		2.42016
4. Bremsbacke mit Belag f. Hinterrad vorn	300c,Sc,SL,SL Roadst.	198 420 02 20		2.42017
5. Bremsbacke mit Belag f. Hinterrad vorn	300S	186 420 05 20		2.42018
6. Bremsbacke mit Belag f. Hinterrad hi. links	300b,d	186 420 43 20		2.42019
7. Bremsbacke mit Belag f. Hinterrad hi. links	300c,Sc,SL,SL Roadst.	198 420 06 20		2.42020
8. Bremsbacke mit Belag f. Hinterrad hi. links	300S	188 420 06 20		2.42021
9. Bremsbacke mit Belag f. Hinterrad hi. rechts	300b,d	186 420 44 20		2.42022
10. Bremsbacke mit Belag f. Hinterrad hi. rechts	300c,Sc,SL,SL Roadst.	198 420 07 20		2.42023
11. Bremsbacke mit Belag f. Hinterrad hi. rechts	300S	188 420 07 20		2.42024
12. Bremsbacke mit Belag f. Hinterrad hinten	300 SL	198 420 03 20		2.42025
13. Radbremszylinder für Hinterradbremse 28,57 mm	300b,S,SL,d,Sc	000 420 42 18		2.42026
14. Radzylinder 22,2 mm	300d,SL Roadster	001 420 22 18		2.42027



Pos.1



Pos.2



Pos.3



Pos.4



Pos.5



Pos.6



Pos.7



Pos.8



Pos.9



Pos.10



Pos.11



Pos.12



Pos.13



Pos.14

	Typenkunde	D. B.	Vergleich.Nr.	LagerNr.
1. Bremszange links	300 SL Roadster	000	423 04 98	2.42028
2. Bremszange rechts	300 SL Roadster	000	423 05 98	2.42029
3. Radzylinder 41,27 mm	300 SL Roadster	001	420 62 18	2.42030
4. Hpt.br.zyl. 25,4 mm	300	000	430 03 01	2.42031
5. Hpt.br.zyl. 25,4 mm	300S	000	430 17 01	2.42032
6. Bremslichtschalter	300b,c	000	545 17 09	2.42033
7. Einkammer Servobremse	300b	000	430 03 30	2.42034
8. Einkammer Servobremse	300b	000	430 04 30	2.42035
9. Einkammer Servobremse	300c	000	430 13 30	2.42036
10. Treadle Vac m. P. ven.	300c,SL	198	430 00 30	2.42037
11. Bremsschlauch vorn	300,b,c,S,SL	000	428 07 35	2.42038
12. Bremsschlauch hinten	300,b,c,S,SL	000	428 08 35	2.42039
13. Hauptzylinder 28,57mm	300d,Sc,SL Roadster	000	430 49 01	2.42040
14. Hauptzylinder 26,99mm	300 SL Roadster	001	430 07 01	2.42041
15. ATE Bremsgerät	300d	000	430 17 30	2.42042
16. ATE Bremsgerät	300 SL Roadster	000	430 15 30	2.42043
17. ATE Bremsgerät	300 Sc	000	430 12 30	2.42044
18. Bremsgerät m. R. ventil	300 SL Roadster	000	430 26 30	2.42045



Pos. 1



Pos. 2



Pos. 3



Pos. 4



Pos. 5



Pos. 6



Pos. 7

Pos. 8

Pos. 9



Pos. 10



Pos. 11



Pos. 12



Pos. 13



Pos. 14

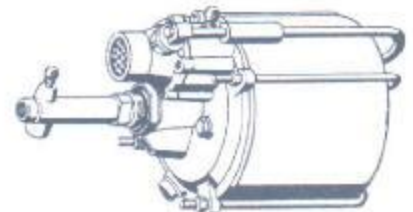

Pos. 15

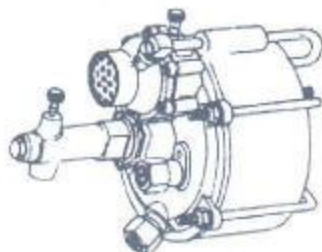

Pos. 16

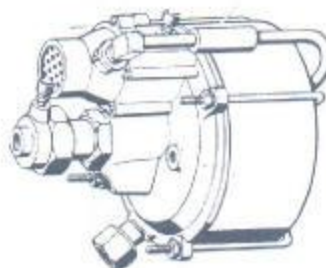

Pos. 17



Pos. 18



Typenkunde

D. B. Vergleich.Nr. LagerNr.

1. Vorderer Bremsseilzug	300	186	420	07	85	2.42046
2. Vorderer Bremsseilzug	300b,c,d	186	420	16	85	2.42047
3. Vorderer Bremsseilzug	300S,Sc	186	420	10	85	2.42048
4. Mittlerer Bremsseilzug	300,S	186	420	08	85	2.42049
5. Mittlerer Bremsseilzug	300b	186	420	18	85	2.42050
6. Mittlerer Bremsseilzug	300c,d	186	420	20	85	2.42051
7. Mittlerer Bremsseilzug	300Sc	188	420	02	85	2.42052
8. Hinterer Bremsseilzug	300,b	186	420	03	85	2.42053
9. Hinterer Bremsseilzug	300c,Sc	186	420	01	85	2.42054
10. Hinterer Bremsseilzug	300d	189	420	00	85	2.42055
11. Hinterer Bremsseilzug	300S	186	420	12	85	2.42056
12. Hinterer Bremsseilzug	300 SL	198	420	01	85	2.42057
13. Hinterer Bremsseilzug	300 SL Roadster	198	420	07	85	2.42058
14. Hinterer Bremsseilzug	300 Sl Roadster	198	420	09	85	2.42059
15. Gummimanschette f. Handbremshebelwelle	300,b,c,d,S,Sc	186	427	00	96	2.42060
16. Lenkung	300,b,S	186	460	12	01	2.46001
17. Lenkung	300b	120	460	25	01	2.46002
18. Lenkung	300c,d,Sc	186	460	31	01	2.46003
17. Lenkung	300SL	198	460	05	01	2.46004

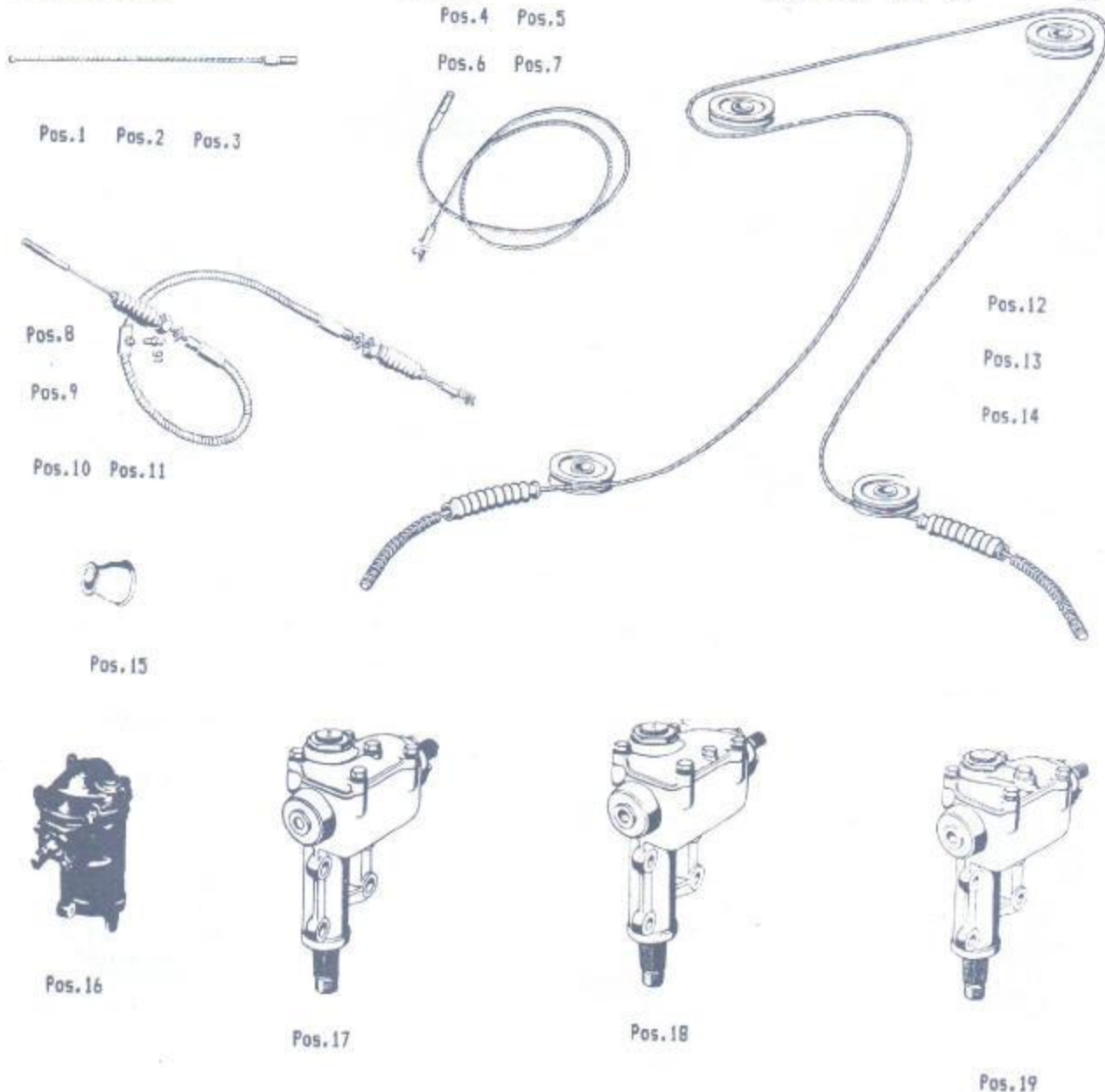

	Typenkunde	D.B.	Vergleich.Nr.	LagerNr.
1.ZF Hydro Lenkung	300d	189	460 03 01	2.46005
2.Lenkrad schwarz	300d	189	464 02 01	2.46006
3.Lenkrad elfenbeinart.	300d	189	464 03 01	2.46007
4.Signalring	300d	189	460 00 40	2.46008
5.Roßlenkung	300 SL	198	460 00 01	2.46009
6.Kreuzgelenk	300SL,SL Roadster	121	462 00 44	2.46010
7.Gelenkscheibe	300,b,c,d,S,Sc	183	462 00 46	2.46011
8.Lenkungsschloß	300,b,S	000	462 02 30	2.46012
9.Lenkungsschloß	300c,d,Sc	000	462 06 30	2.46013
10.Lenkungsschloß	300 SL Roadster	000	462 19 30	2.46014
11.Lenkrad schwarz	300,b,c,d,S,Sc,SL Ro.	186	460 08 03	2.46015
12.Lenkrad elfenb.	300c,d,Sc,SL Roadster	186	460 08 03	2.46015
13.Lenkrad schwarz Autom.	300c,d	120	464 08 01	2.46016
14.Lenkrad elfenb. Autom.	300c,d	120	464 029 01	2.46017
15.Lenkrad elfenb.	300d	111	464 09 01	2.46018
16.Lenkrad schwarz	300d	111	464 08 01	2.46019
17.Lenkrad	300SL	198	464 01 01	2.46020
18.Signalringnabe schwarz	300d	111	464 03 36	2.46021
19.Signalringn. elfenb	300d	111	464 05 36	2.46022
20.Signalring	300d	111	464 06 15	2.46023
21.Firmenzeichen schwarz	300d	111	460 04 42	2.46024
22.Firmenzeichen elfenb.	300d	111	460 04 42	2.46025
23.Lenkstange	300 SL Roadster	198	460 05 05	2.46026

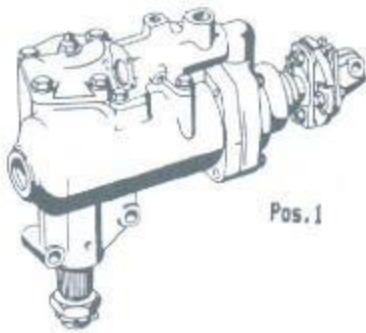

Pos.1



Pos.2 Pos.3



Pos.4

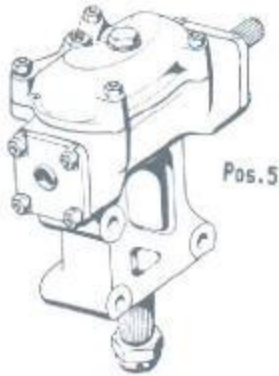

Pos.5

Pos.6



Pos.7



Pos.8



Pos.9



Pos.10



Pos.11 Pos.12

Pos.13 Pos.14



Pos.15 Pos.16



Pos.17



Pos.18 Pos.19



Pos.20



Pos.21 Pos.22



Pos.23



## Typenkunde

D. B. Vergleich.Nr. LagerNr.

	Typenkunde	D. B. Vergleich.Nr.	LagerNr.
1. Lenkungsstoßdämpfer	300 SL Roadster	000 460 02 66	2.46027
2. Elektr. Geber f. Tank	300, b, c	186 542 05 04	2.47001
3. Tankverschluß a. Aufsatz	300SL, SL Roadster	198 471 00 30	2.47002
4. Gummimanschette f. Einfüllstutzen unten	300, b, c, d, S, Sc	183 471 01 81	2.47005
5. Gummimanschette f. Einfüllstutzen oben	300, b, c, d, S, Sc	183 471 00 81	2.47006
6. Auspuffüberrohrblende	300 SL	198 492 14 00	2.49001
7. Auspuffüberrohrblende	300 SL Roadster	198 490 00 27	2.49002

Weitere Auspuffteile siehe Seite !!!!

8. Kühlwasserregler	300, b, S	000 203 26 75	2.50001
9. Kühlwasserregler	300c, d, Sc	000 203 43 75	2.50002
10. Kühlwasserregler	300d	001 203 11 75	2.50003
11. Kombi-Instrument	alle 300 Modelle	186 542 02 01	2.54001
12. Zeituhr	300, b, S, d, Sc	186 542 03 11	2.54002
13. Fernl. - Blinksch. schwarz	300c	000 454 42 24	2.54003
14. Fernl. - Blinksch. elfenbeinartig	300c	000 454 43 24	2.54004
15. Tachowelle	300, b	186 542 00 07	2.54005
16. Tachowelle f. Autom.	300c	186 542 02 07	2.54006
17. Tachowelle	300c, S, Sc	188 542 00 07	2.54007
18. Fußabblendschalter	300b, d, Sc, c, S	000 545 04 12	2.54008



Pos. 1



Pos. 2



Pos. 3



Pos. 4



Pos. 5



Pos. 6



Pos. 7



Pos. 8



Pos. 9



Pos. 10



Pos. 11



Pos. 12

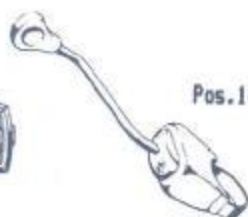

Pos. 13

Pos. 14



Pos. 15



Pos. 16



Pos. 18

Pos. 17

Auspuffanlagen	Typenkunde	LagerNr.
1. Auspuffanlage komplett Edelstahl	300	2.49003

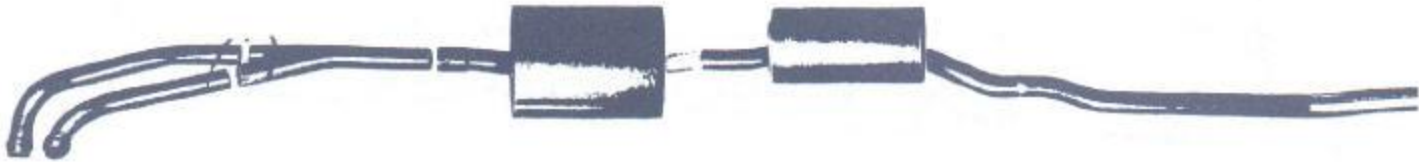

2. Auspuffanlage komplett Edelstahl	300b	2.49004
-------------------------------------	------	---------

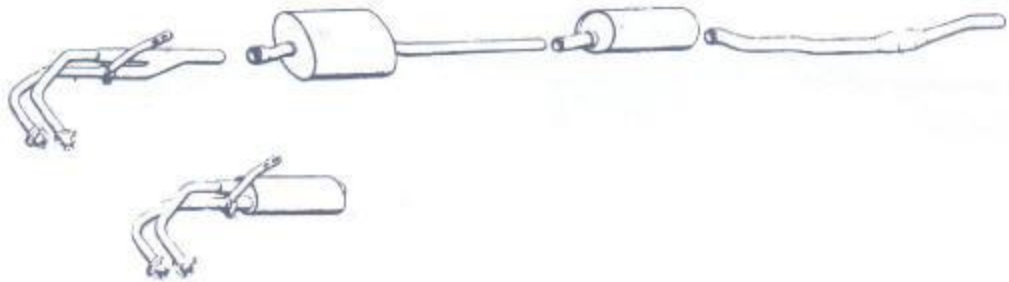

3. Auspuffanlage komplett Edelstahl	300c	2.49005
-------------------------------------	------	---------





Auspuffanlagen

Typenkunde

LagerNr.

1. Auspuffanlage komplett Edelstahl	300d	2.49006
-------------------------------------	------	---------



2. Auspuffanlage komplett Edelstahl	300S	2.49007
-------------------------------------	------	---------

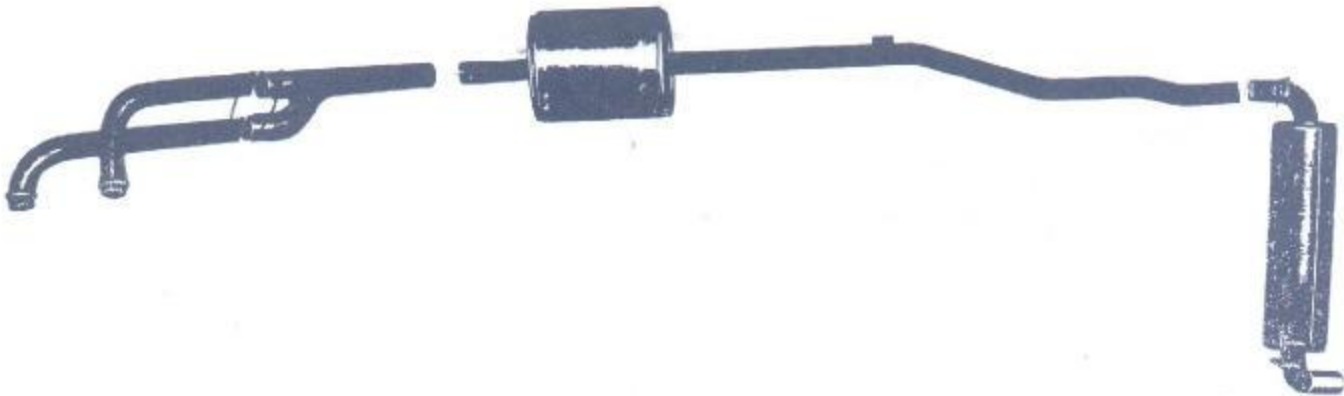

3. Auspuffanlage komplett Edelstahl	300Sc	2.49008
-------------------------------------	-------	---------



Auspuffanlagen

Typenkunde

LagerNr.

1. Auspuffanlage komplett Edelstahl	300SL	2.49009
-------------------------------------	-------	---------

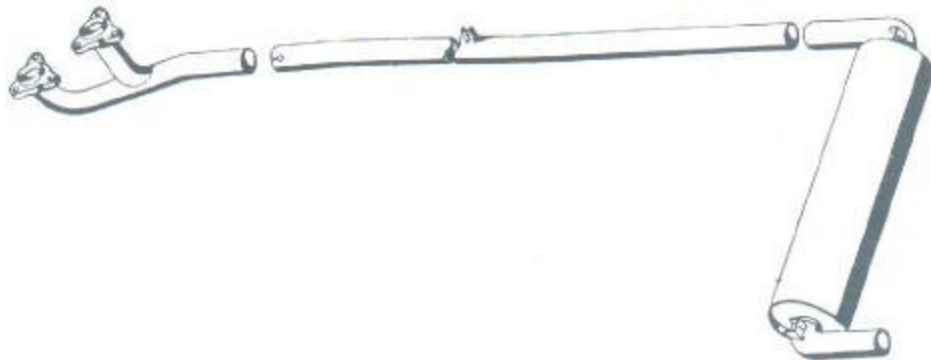

2. Auspuffanlage komplett Edelstahl	300SL Roadster	2.49010
-------------------------------------	----------------	---------

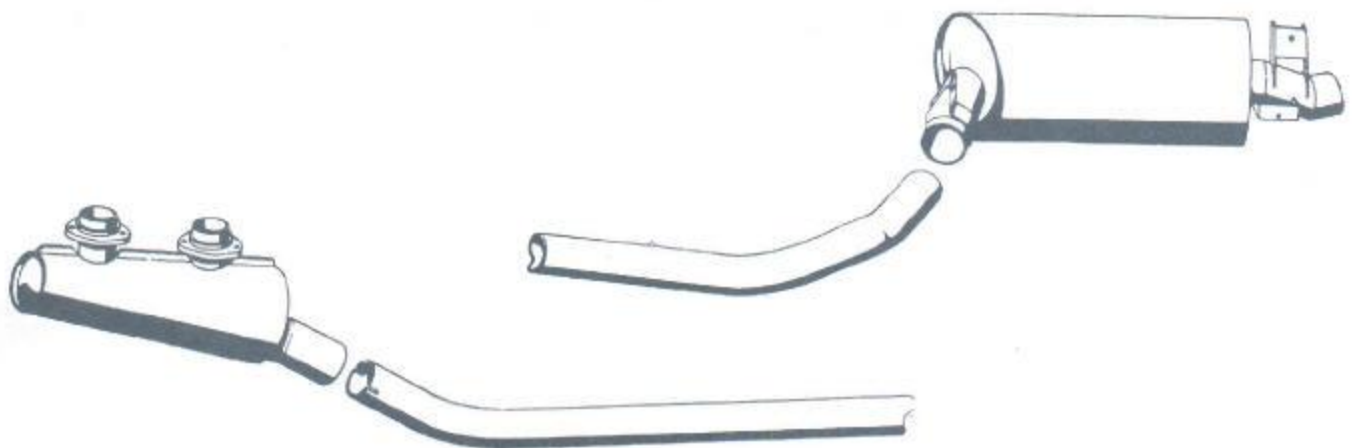



## Typenkunde

## D. B. Vergleich.Nr. LagerNr.

	Typenkunde	D. B. Vergleich.Nr.	LagerNr.
1. Eindruckschmierpumpe	300b,c,Sc	000 571 19 01	2.57001
2. Schmierölleitung Kupfer 8*0.8 mm	300,b,c,d,S,Sc		2.57002
3. Dichtkegel von Nach- füllbehälter zur Pumpe	300,b,c,d,S,Sc		2.57003
4. Rohrverschraubung	300,b,c,d,S,Sc		2.57004
5. Verb. schlauch für Schmierltg. z. Kupplunglg.	300,b,d,S,Sc	183 570 01 36	2.57005
6. Verb. schlauch von Vert. z. Lenkungs-Zw.hebel	300,b,c,d		2.57006
7. Verb. schlauch zum Lenkungszw.hebel	300c,d,S,Sc		2.57007
8. Verb. schlauch von T-Stck. z. Vert. Achssch.	300,b,c,d,S,Sc		2.57008
9. Verb. schlauch von Schmierölltg. z. Lagerk.	300,d,S		2.57009
10. Verb. schlauch von Schmierölltg. z. Lagerk.	300b		2.57010
11. Verb. schlauch für Schmierölltg. Gelenkw.	300c,Sc		2.57011
12. Schmierölleitung Kupfer 4*0.8 mm	300,b,c,d,S,Sc		2.57012
13. Dichtkegel	300,b,c,d,S,Sc		2.57013
14. Rohrverschraubung	300,b,c,d,S,Sc		2.57014



Pos. 1



Pos. 2



Pos. 3



Pos. 4



Pos. 5



Pos. 6



Pos. 7



Pos. 8



Pos. 9 Pos. 10



Pos. 11



Pos. 12



Pos. 13



Pos. 14

	Typenkunde	D. B.	Vergleich.Nr.	LagerNr.
1. Glasscheibe für Wind- schuttscheibe	300,b,c	10 186 671 00 10		2.67001
2. Windschutzscheibe	300d	10 189 671 00 10		2.67002
3. Glasscheibe für Wind- schuttscheibe	300S,Sc	30 188 671 01 10		2.67003
4. Glasscheibe für Wind- schuttscheibe	300SL	40 198 671 00 10		2.67004
5. Glasscheibe für Wind- schuttscheibe	300 SL Roadster	42 198 671 00 10		2.67005
6. Unterlage für Quer- bügel unter Windsch. 1600mm	300 SL	000 987 38 51		2.67006
7. Dichtungsrahmen	300d	10 189 671 00 20		2.67007
8. Dichtungsrahmen	300,b,c	10 186 671 00 20		2.67008
9. Dichtungsrahmen	300S,Sc	30 188 671 00 20		2.67009
10. Dichtungsrahmen	300SL	40 198 671 00 20		2.67010
11. Dichtungsrahmen	300 SL Roadster	42 198 671 00 20		2.67011
12. Abdichtungsrahmen f. Seitenfenster li.	300SL	40 198 673 01 20		2.67012
13. Abdichtungsrahmen f. Seitenfenster re.	300SL	40 198 673 02 20		2.67013
14. Dichtungsrahmen für Rückwandfenster	300,300b	10 186 678 00 20		2.67014
15. Dichtungsrahmen für Rückwandfenster	300d	10 189 670 00 39		2.67015
16. Dichtungsrahmen für Rückwandfenster	300S	10 188 678 00 20		2.67016
17. Dichtungsrahmen für Rückwandfenster	300SL	40 198 678 00 20		2.67017

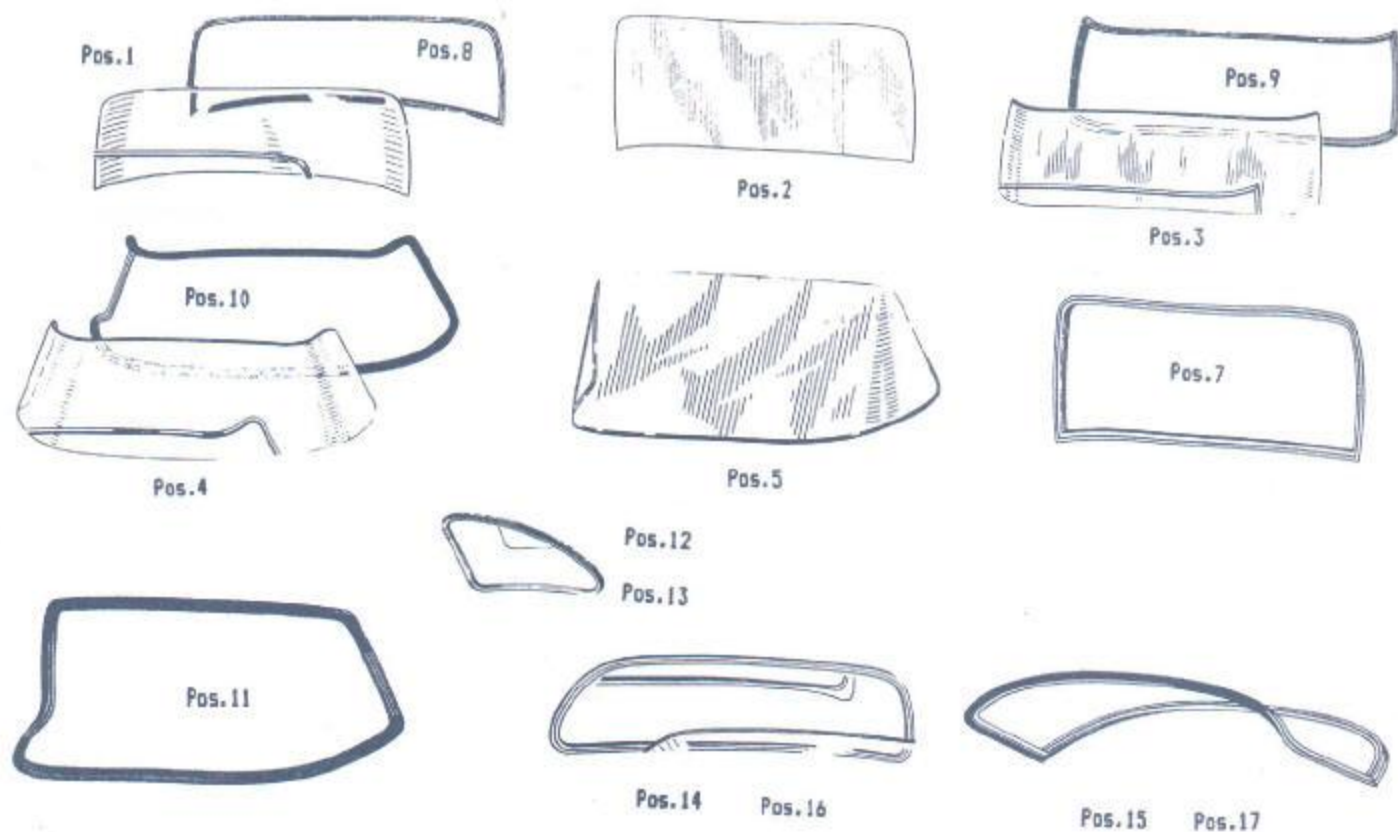



Typenkunde	D. B. Vergleich.Nr.	LagerNr.
1. Gummibelag links für 300b Einstieg vorn	10 186 686 05 80	2.68001
2. Gummibelag rechts für 300b Einstieg vorn	10 186 686 06 80	2.68002
3. Einstiegschiene 300,b,c,d li. u.re. f.Fahrert.	10 186 686 00 20	2.68003
4. Gummibelag links für 300b,c Einstieg hinten	10 186 686 05 81	2.68004
5. Gummibelag rechts für 300b,c Einstieg hinten	10 186 686 06 81	2.68005
6. Einstiegschiene li. 300,b,c u. re.f.Fondtür f.Einst.hi.	10 186 686 00 22	2.68006
7. Gummibelag links für 300d Einstieg hinten	10 189 686 01 81	2.68007
8. Gummibelag rechts für 300d Einstieg hinten	10 189 686 02 81	2.68008
9. Einstiegsch. Fondtür 300d	10 186 686 01 22	2.68009
10. Zierstab li.a.Seiten- 300 SL teil unten	40 198 690 03 80	2.69001
11. Zierstab re.a.Seiten- 300 SL teil unten	40 198 690 04 80	2.69002
12. Zierstab li.a.Seiten- 300 SL wand am Luftaustr.	40 198 698 01 80	2.69003
13. Zierstab re.a.Seiten- 300 SL wand am Luftaustr.	40 198 698 02 80	2.69004
14. Zierstab li. oben an 300 SL Roadster Seitenwand Luftaustr.	42 198 690 01 80	2.69005
15. Zierstab re. oben an 300 SL Roadster Seitenwand Luftaustr.	42 198 690 02 80	2.69006
16. Zierstab re. unten 300 SL Roadster Seitenwand Luftaustr.	42 198 690 04 80	2.69007
17. Zierstab li. unten 300 SL Roadster Seitenwand Luftaustr.	42 198 690 03 80	2.69008

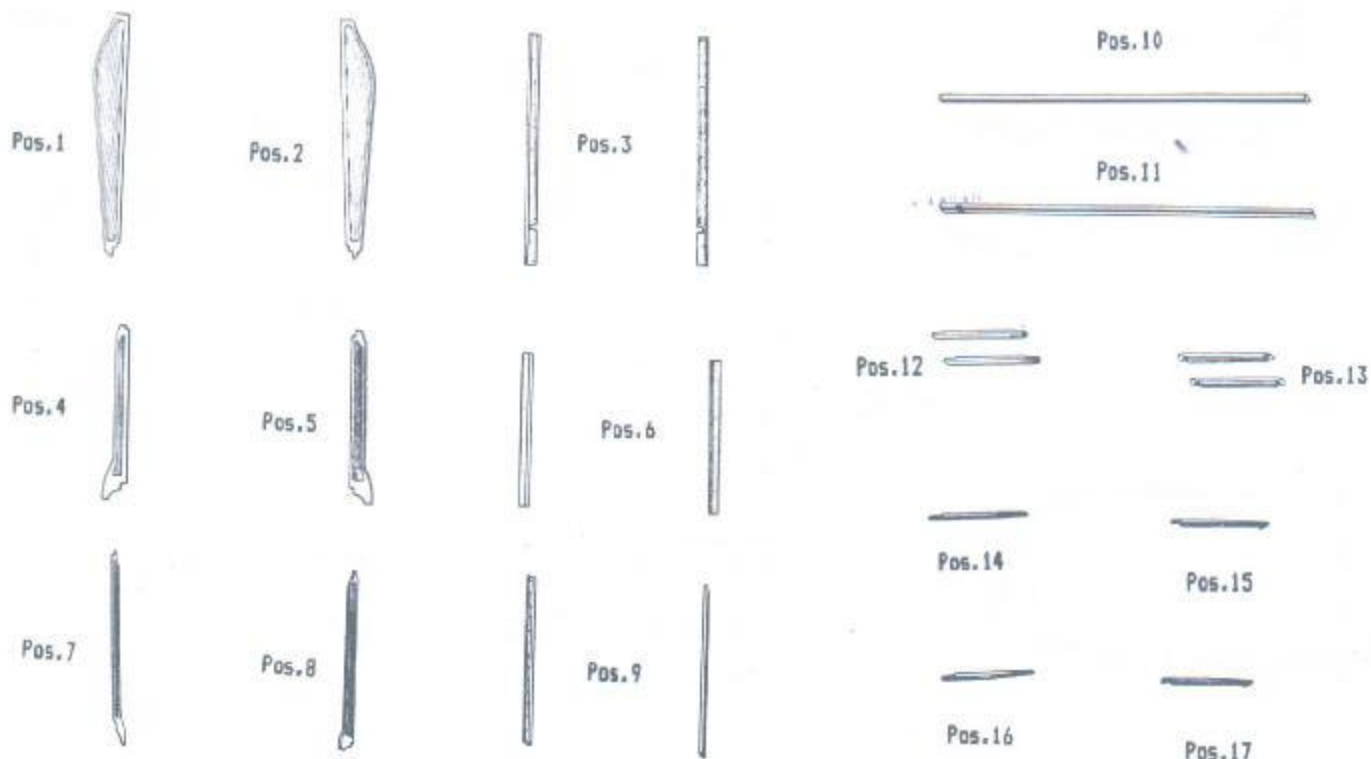

	Typenkunde	D. B. Vergleich.Nr.	LagerNr.
1. Zierstab an Seitenw.	300 SL Roadster	42 198 698 05 80	2.69009
2. Zierstab unten hinten links	300 SL Roadster	42 198 698 05 80	2.69010
3. Zierstab unten rechts	300 SL Roadster	42 198 698 06 80	2.69011
4. Türgriff verschl. f. linke Fahrertür	300,b,c,d,S,Sc	12 136 766 12 01	2.72001
5. Türgriff unverschl. f. li. u.re.Tür	300,b,c,d,S,Sc	12 136 766 11 01	2.72002
6. Gummiunterlage Türgr.	300,b,c,d	12 136 766 00 05	2.72003
7. Türziehgriff	300,b,c,d	12 136 766 00 09	2.72004
8. Fensterpresser außen	300,b,c,d,S,Sc	10 186 768 00 11	2.72005
9. Fensterpr. innen li.	300,b,c,d,S,Sc	10 186 768 01 11	2.72006
10. Fensterpr. innen re.	300,b,c,d,S,Sc	10 186 768 02 11	2.72007
11. Kurbel	300,b,c,d	12 136 768 00 02	2.72008
12. Kurbel	300d	189 768 01 02	2.72009
13. Türabdichtung links	300,b,c	10 186 720 01 78	2.72010
14. Türabdichtung rechts	300,b,c	10 186 720 02 78	2.72011
15. Türabdichtung links	300,b,c,d Cabrio	40 186 720 01 78	2.72012
16. Türabdichtung rechts	300,b,c,d Cabrio	40 186 720 02 78	2.72013
17. Türabdichtung links	300Sc/Ac,/R	30 188 720 01 78	2.72014
18. Türabdichtung rechts	300Sc/Ac,/R	30 188 720 02 78	2.72015
19. Türabdichtung links	300Sc/CP	10 188 720 01 78	2.72016
20. Türabdichtung rechts	300Sc/CP	10 188 720 02 78	2.72017

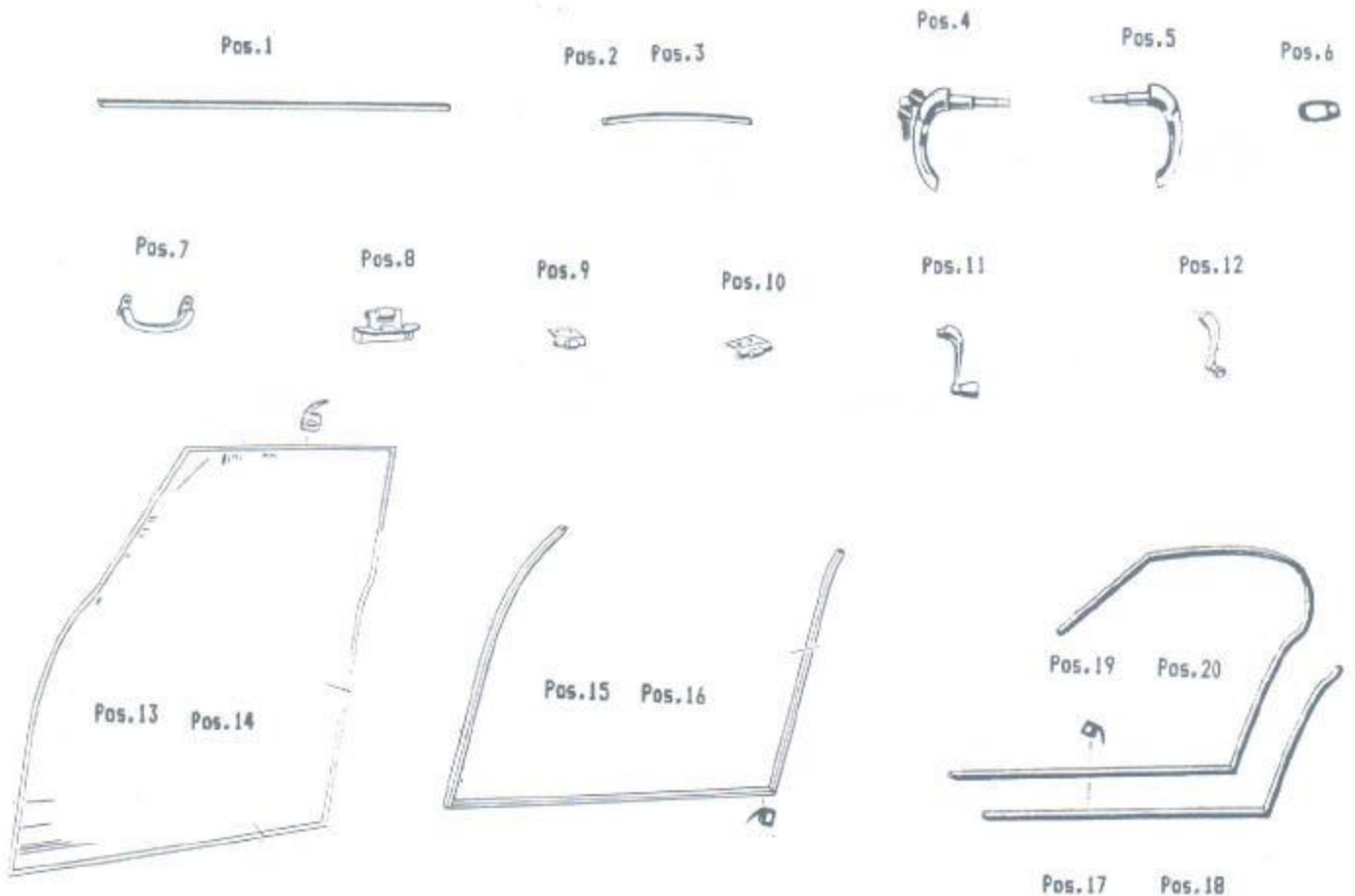



	Typenkunde		D. B. Vergleich.Nr.	LagerNr.
1. Hackenschloß f. linke Fahrertür	300 SL		40 198 720 03 35	2.72018
2. Hackenschloß f. rechte Fahrertür	300 SL		40 198 720 04 35	2.72019
3. Verschuß f. linke u. rechte Fahrertür	300 SL		40 198 766 00 26	2.72020
4. Zierrahmen f. Türf.li.	300 SL		40 198 720 01 53	2.72021
5. Zierrahmen f. Türf.re.	300 SL		40 198 720 02 53	2.72022
6. Fensterversch. links	300 SL		40 198 720 01 32	2.72023
7. Fensterversch. rechts	300 SL		40 198 720 02 32	2.72024
8. Dichtungsrahmen für Fahrertür	300 SL		40 198 727 00 30	2.72025
9. Dichtungsrahmen für Fahrertür links	300 SL		40 198 727 01 30	2.72026
10. Dichtungsrahmen für Fahrertür rechts	300 SL		40 198 727 02 30	2.72027
11. Außendrücker links	300 SL Roadster		42 198 766 01 02	2.72028
12. Außendrücker rechts	300 SL Roadster		42 198 766 02 02	2.72029
13. Zylinderverschluß	300 SL Roadster		42 198 766 01 26	2.72030
14. Fensterkurbel	300 SL Roadster		40 121 768 01 02	2.72031
15. Rosette f. Kurbel	300 SL Roadster		12 136 768 00 03	2.72032
16. Abd.gummi links für Verdeckrahmen seitlich hi.	300 SL Roadster		42 198 725 07 66	2.72033
17. Abd.gummi rechts für Verdeckrahmen seitlich hi.	300 SL Roadster		42 198 725 08 66	2.72034



Pos.1



Pos.2



Pos.3



Pos.4 Pos.5



Pos.6 Pos.7

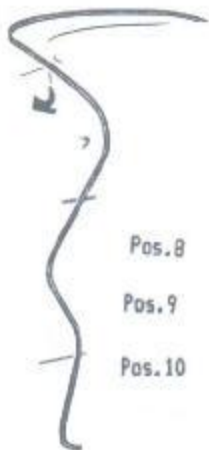

Pos.8

Pos.9

Pos.10



Pos.11



Pos.12



Pos.13



Pos.14



Pos.15



Pos.16

Pos.17

Typenkunde		D. B. Vergleich.Nr.				LagerNr.
1. Abdichtungsr. links	300 SL Roadster	42	198	720	01 78	2.72035
2. Abdichtungsr. rechts	300 SL Roadster	42	198	720	02 78	2.72036
3. Abdichtungsr. links	300, a, b, c, d					2.73001
4. Abdichtungsr. rechts	300, a, b, c, d					2.73002
5. Fensterpresser außen	300, b/CD	10	186	768	01 11	2.73003
6. Schutzkappe Fondt. li.	300d	10	189	730	01 82	2.73004
7. Schutzkappe Fondt. re.	300d	10	189	730	02 82	2.73005
8. Schutzkappe Fondt. li.	300b, c	10	186	730	01 82	2.73006
9. Schutzkappe Fondt. re.	300b, c	10	189	730	02 82	2.73007
10. Abd. köder f. Schutzk.	300b, c		000	987	04 31	2.73008
11. M. B. Stern a. H. deck.	300, b, c	10	186	750	00 79	2.75001
12. Stern verchr. a. H. d.	300S, Sc	30	188	750	00 79	2.75002
13. Deckelgriff verschl.	300, b, c, S, Sc	10	186	750	00 79	2.75003
14. Gummirosette	300, b, c, S, Sc		000	758	00 05	2.75004
15. Druckschloß f. H. deckel	300d	10	189	750	00 84	2.75005
16. Gummischeibe f. D. sch.	300d		189	987	00 41	2.75006
17. Sicherungsblech	300d		189	994	00 21	2.75007
18. Typenk. zeichen "300"	300, b	10	186	810	00 71	2.75008
19. Typenk. zeichen "300"	300c	10	186	810	01 71	2.75009
20. Typenk. zeichen "300"	300d	10	186	817	00 15	2.75010
21. Typenk. zeichen "300S"	300S, Sc	30	188	817	00 15	2.75011
22. Abdichtg. f. H. deckel	300, b, c, S, Sc		000	987	87 36	2.75012
23. Abdichtg. f. H. deckel	300d	10	189	750	00 77	2.75013
24. Griff f. H. deckel	300d	10	180	758	00 02	2.75014
25. Gummiunterlage	300d	10	180	758	00 90	2.75015

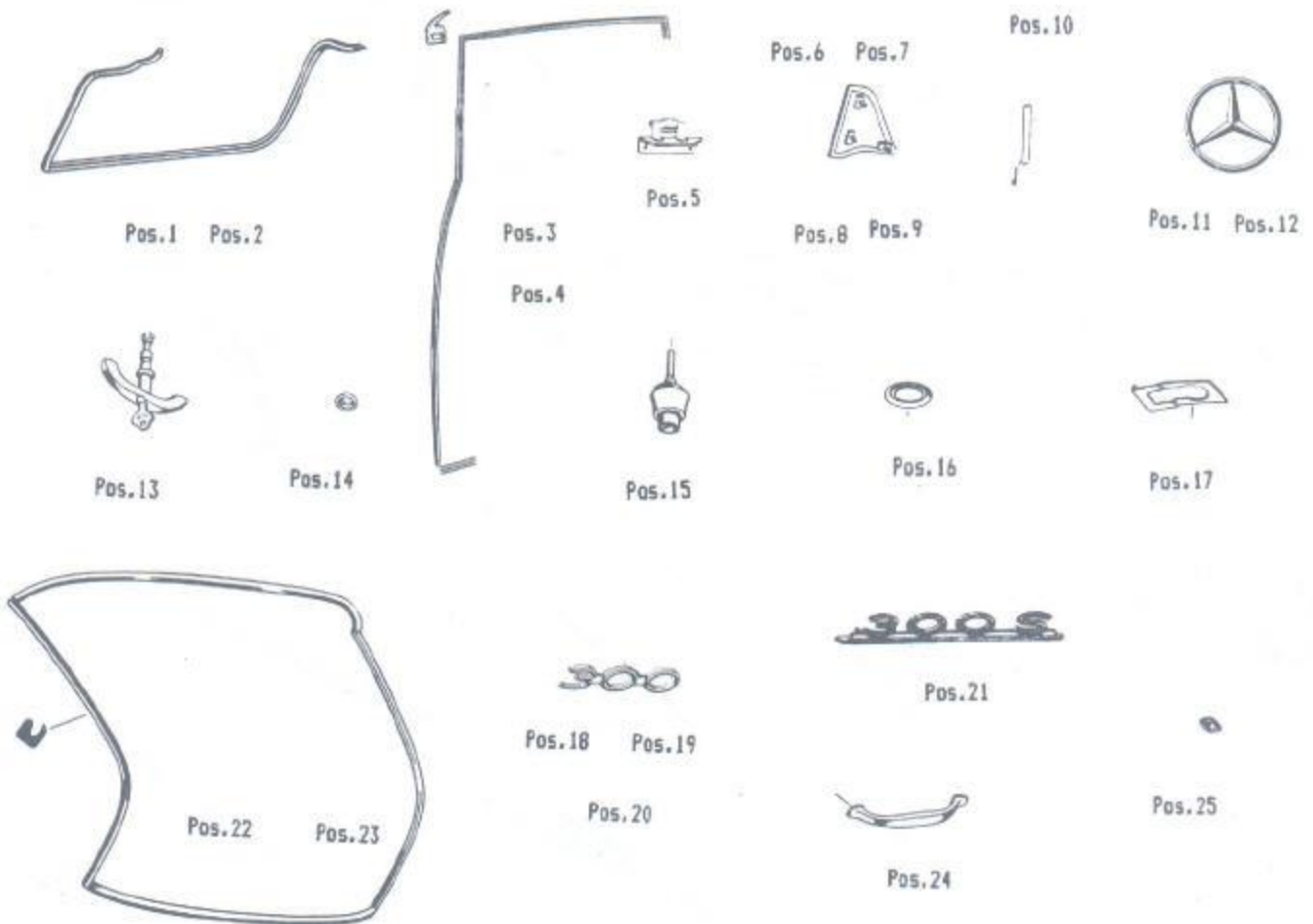



Typenkunde

D.B. Vergleich.Nr. LagerNr.

1. Verschuß Heckdeckel	300 SL	40 198 750 00 84	2.75016
2. Verschuß Heckdeckel mit vergoldetem Schlüssel	300 SL Roadster	42 198 750 00 84	2.75017
3. Gummiunterlage	300 SL	40 198 758 00 96	2.75018
4. Gummiunterlage	300 SL	13 136 758 00 98	2.75019
5. M. Stern Heckdeckel	300 SL Roadster	30 188 750 00 79	2.75020
6. Heckdeckeldichtung	300 SL, SL Roadster		2.75021
7. Typenkennz. "300 SL"	300SL, SL Roadster	40 198 817 00 15	2.75022
8. Rückblickspiegel	300, b, c, S, Sc	40 186 810 00 17	2.81001
9. Rückblickspiegel li.	300/CD, b/CD, c	40 186 810 00 16	2.81002
10. Rückblickspiegel li.	300d	10 189 810 01 16	2.81003
11. Rückblickspiegel li.	300 SL	40 198 810 00 16	2.81004
12. Rückblicksp. verchr.	300 SL	40 198 810 00 17	2.81005
13. Rückblickspiegel	300 SL Roadster	40 198 810 00 16	2.81006
14. Firmenz. außen Bug	300 SL, SL Roadster	40 198 817 00 16	2.81007
15. Wischerarm m. G. stück	300, b, c, d	10 186 824 01 28	2.82001
16. Wischerarm m. G. stück	300S, Sc	30 188 824 00 28	2.82002
17. Wischerblatt	300b, c, d	10 186 824 00 26	2.82003
18. Wischerblatt	300S, Sc	30 188 824 00 26	2.82004
19. Wischreblatt verchr.	300 SL	30 188 824 00 26	2.82005
20. Wischerarm verchr.	300 SL	40 198 824 00 28	2.82006
21. Wischerblatt links	300 SL Roadster	42 198 824 01 26	2.82007
22. Wischerblatt rechts	300 SL Roadster	42 198 824 02 26	2.82008
23. Wischerarm links	300 SL Roadster	42 198 824 01 28	2.82009
24. Wischerarm rechts	300 SL Roadster	42 198 824 02 28	2.82010

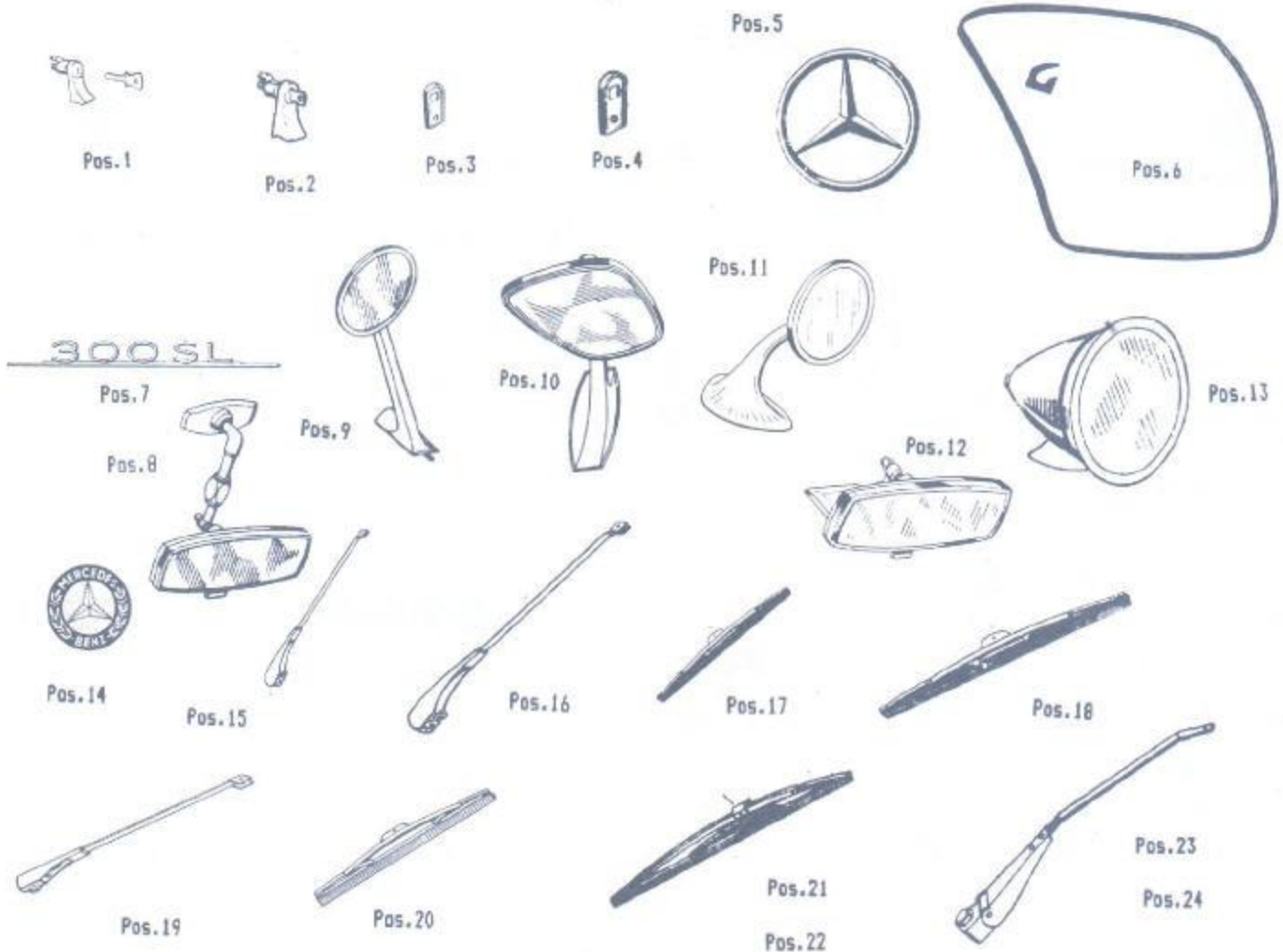

	Typenkunde	D. B. Vergleich.Nr.				LagerNr.
1. Einbauscheinwerfer	300, b, c	10	186	820	00 61	2.82011
2. Einbauscheinwerfer	300S, Sc	30	188	820	00 61	2.82012
3. Glasscheibe	300b, c		000	826	19 90	2.82013
4. Zierring verchromt	300, b, c	10	186	826	00 89	2.82014
5. Zierring verchromt	300S, Sc	30	188	826	00 89	2.82015
6. Einbauscheinw. asym.	300d		000	544	33 02	2.82016
7. Zierring	300d		000	544	67 89	2.82017
8. Tragring	300d		000	544	00 83	2.82018
9. Einbauscheinwerfer	300 SL		000	577	12 02	2.82019
10. Zierring	300 SL		000	544	09 89	2.82020
11. Einbauscheinwerfer mit Sealed Beam Eins.	300 SL		000	540	07 56	2.82021
12. Zierring	300 SL		000	544	37 89	2.82022
13. Sealed Beam Einsatz	300 SL		000	544	02 18	2.82023
14. Leuchteinheit	300 SL Roadster		198	820	00 61	2.82024
15. Leuchteinheit ohne S. B. Eins. Blinkl. Hpt. Nebelscheinw.	300 SL Roadster		000	540	24 56	2.82025
16. Nebelleuchte	300, b, S, Sc		000	544	13 06	2.82026
17. Nebelleuchte glask.	300c		000	544	30 06	2.82027
18. Nebelscheinwerfer	300d		000	544	42 06	2.82028
19. Deckel li. f. Brems- Schlußleuchte	300, b, c	10	186	826	01 52	2.82029
20. Deckel rechts	300, b, c	10	186	826	02 52	2.82030
21. Deckel links verchr.	300S, Sc	30	188	826	01 52	2.82031
22. Deckel re. verchr.	300S, Sc	30	188	826	02 52	2.82032

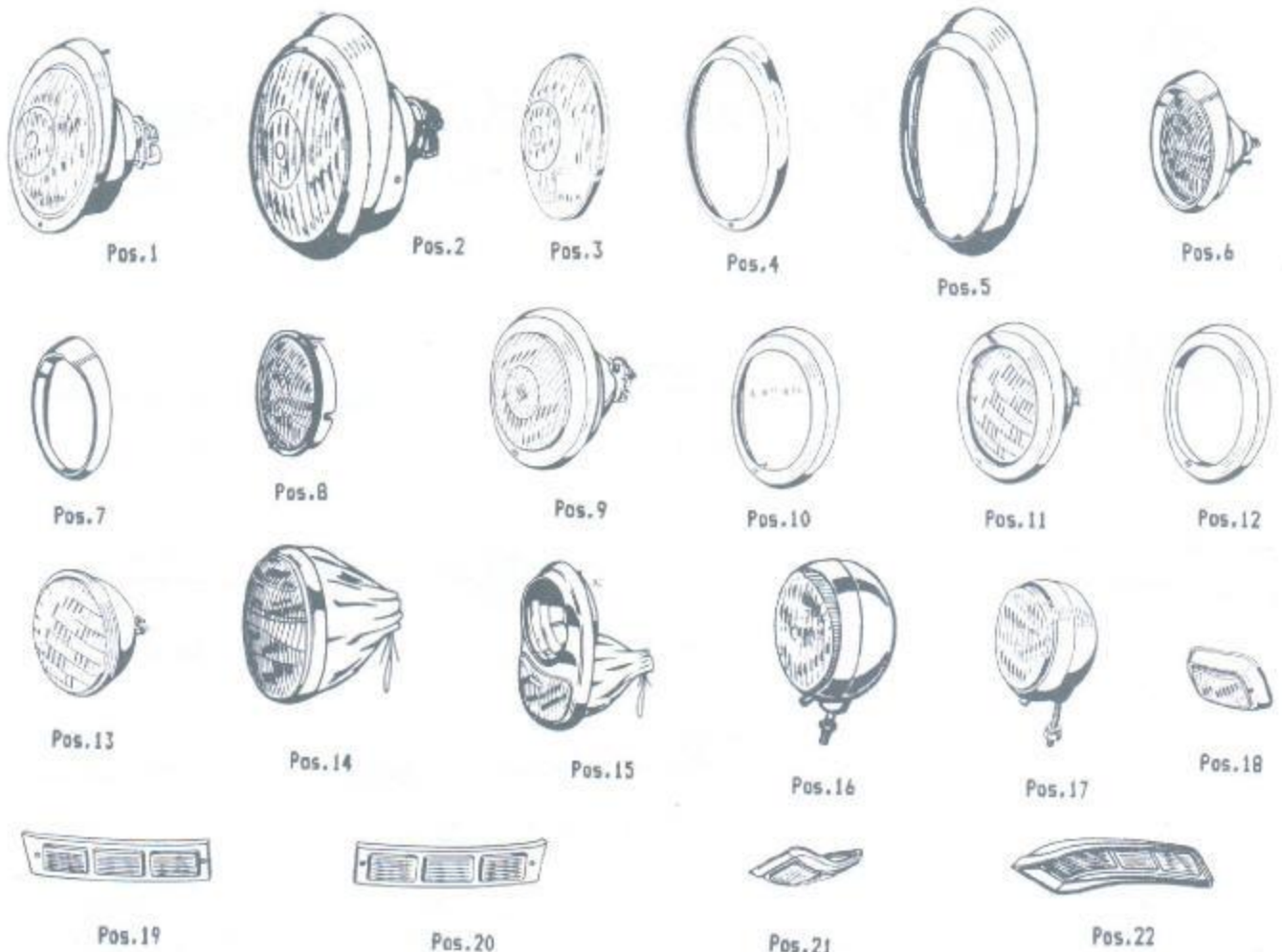



Typenkunde

D. B. Vergleich.Nr. LagerNr.

1. Rückleuchte	300d	30	180	820	02	64	2.82033
2. Rückleuchte Sw. Austr.	300d	30	180	820	02	64	2.82034
3. Deckelrahmen links	300 SL	40	198	820	01	78	2.82035
4. Deckelrahmen rechts	300 SL	40	198	820	02	78	2.82036
5. Deckel rechts	300 SL Roadster		000	544	03	28	2.82037
6. Deckel links	300 SL Roadster		000	544	04	28	2.82038
7. Gehäuse verchr. m. Glas	300, b	10	186	820	00	27	2.82039
8. Gehäuse	300c	10	186	820	02	27	2.82040
9. Gehäuse verchromt	300Sc	30	188	820	02	27	2.82041
10. Glasscheibe m. Dichtg.	300b, Sc		000	544	31	90	2.82042
11. Lichtscheibe glask.	300c, Sc	10	186	822	01	27	2.82043
12. Gummiunterlage	300b, S	10	186	822	01	25	2.82044
13. Unterlage f. Blinkl. vo.	300c, Sc	10	186	820	00	96	2.82045
14. Blink-Parkl. vorn li.	300d		000	544	21	30	2.82046
15. Blink-Parkl. vorn re.	300d		000	544	20	30	2.82047
16. Lichtscheibe links	300d		000	544	77	90	2.82048
17. Lichtscheibe rechts	300d		000	544	76	90	2.82049
18. Gummiunterlage	300d		000	544	07	24	2.82050
19. Unterlage Blinkl. hi.	300b, S	10	186	822	01	26	2.82051
20. Unterlage	300c, Sc	10	186	820	02	96	2.82052
21. Gehäuse links	300, b	10	186	820	01	28	2.82053
22. Gehäuse links	300c, Sc	10	186	820	03	28	2.82054
23. Gehäuse rechts	300, b	10	186	820	02	28	2.82055
24. Gehäuse rechts	300c, Sc	10	186	820	04	28	2.82056



Pos. 1



Pos. 2



Pos. 3



Pos. 4



Pos. 6



Pos. 5



Pos. 7



Pos. 8



Pos. 9



Pos. 10



Pos. 11



Pos. 12



Pos. 13



Pos. 14



Pos. 15



Pos. 16



Pos. 17



Pos. 18

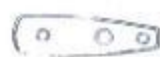

Pos. 19



Pos. 20



Pos. 21



Pos. 23



Pos. 22



Pos. 24

Typenkunde		D.B. Vergleich.Nr.					LagerNr.
1. Kennzeichenbel. links	300b,c	10	186	820	05	62	2.82057
2. Kennzeichenbel. re.	300b,c	10	186	820	06	62	2.82058
3. Kennzeichenbel. links	300Sc	10	188	820	02	62	2.82059
4. Kennzeichenbel. re.	300Sc	10	188	820	00	62	2.82060
5. Kennzeichenl. links	300d		180	540	02	04	2.82061
6. Kennzeichenl. rechts	300d		180	540	03	04	2.82062
7. Kennzeichenbel. links	300 SL	40	198	820	01	62	2.82063
8. Kennzeichenbel. re.	300 SL	40	198	820	02	62	2.82064
9. Kennzeichenbel. links	300 SL Roadster	10	180	820	03	62	2.82065
10. Kennzeichenbel. re.	300 SL Roadster	10	180	820	04	62	2.82066
11. Rückstrahler	300b,c,S,Sc	10	186	826	01	40	2.82067
12. Wasserbehälter	300c,Sc		000	869	02	20	2.82068
13. Wasserbehälter	300d,SL Roadster		000	869	07	20	2.82069
14. Wasserbehälter	300 SL		000	869	01	20	2.82070
15. Steinschlagschutz li.	300S	30	188	880	01	26	2.88001
16. Steinschlagschutz re.	300S	30	188	880	02	26	2.88002
17. Steinschlagschutz li.	300Sc	30	188	880	03	26	2.88003
18. Steinschlagschutz re.	300Sc	30	188	880	04	26	2.88004



Pos.1 Pos.3



Pos.2 Pos.4



Pos.7



Pos.8



Pos.5

Pos.9



Pos.6

Pos.10



Pos.11



Pos.12 Pos.13



Pos.14



Pos.15



Pos.16



Pos.17



Pos.18



Typenkunde	D. B. Vergleich.Nr.	LagerNr.
1. Verkleidung unten vo. 300 SL	40 198 880 01 44	2.88005
2. Verkl. unten Mitte 300 SL	40 198 880 05 44	2.88006
3. Verkl. unten hinten 300 SL	40 198 880 01 44	2.88007
4. Gummistreifen f. Verkl. (3*20) 300 SL	000 987 01 14	2.88008
5. Gummistreifen f. Verkl. (10*30) 300 SL	000 987 02 14	2.88009
6. Asbestband Auspuffs. 300 SL	000 989 06 80	2.88010
7. Verkleidung li. unten 300 SL	40 198 884 03 31	2.88011
8. Verkleidung re. unten 300 SL	40 198 884 04 31	2.88012
9. Federmutter f. Verkl. 300 SL	000 990 10 45	2.88013
10. Terostat 300 SL	000 990 47 85	2.88014
11. Verkleidung unten Mitte ü. Ausppuff 300 SL	40 198 880 06 44	2.88015
12. Verkleidung unten hinten ü. Ausppuff 300 SL	40 198 880 07 44	2.88016
13. Kotflügelstck li. vo. 300 SL	40 198 880 01 18	2.88017
14. Kotflügelstck re. vo. 300 SL	40 198 880 02 18	2.88018
15. Kotflügelstck li. hi. 300 SL	40 198 880 01 21	2.88019
16. Kotflügelstck re. hi. 300 SL	40 198 880 02 21	2.88020
17. Kotflügelstck li. vo. 300 SL Roadster	42 198 880 03 18	2.88021
18. Kotflügelstck re. vo. 300 SL Roadster	42 198 880 04 18	2.88022
19. Kotflügelstck li. hi. 300 SL Roadster	42 198 880 03 21	2.88023
20. Kotflügelstck re. hi. 300 SL Roadster	42 198 880 04 21	2.88024

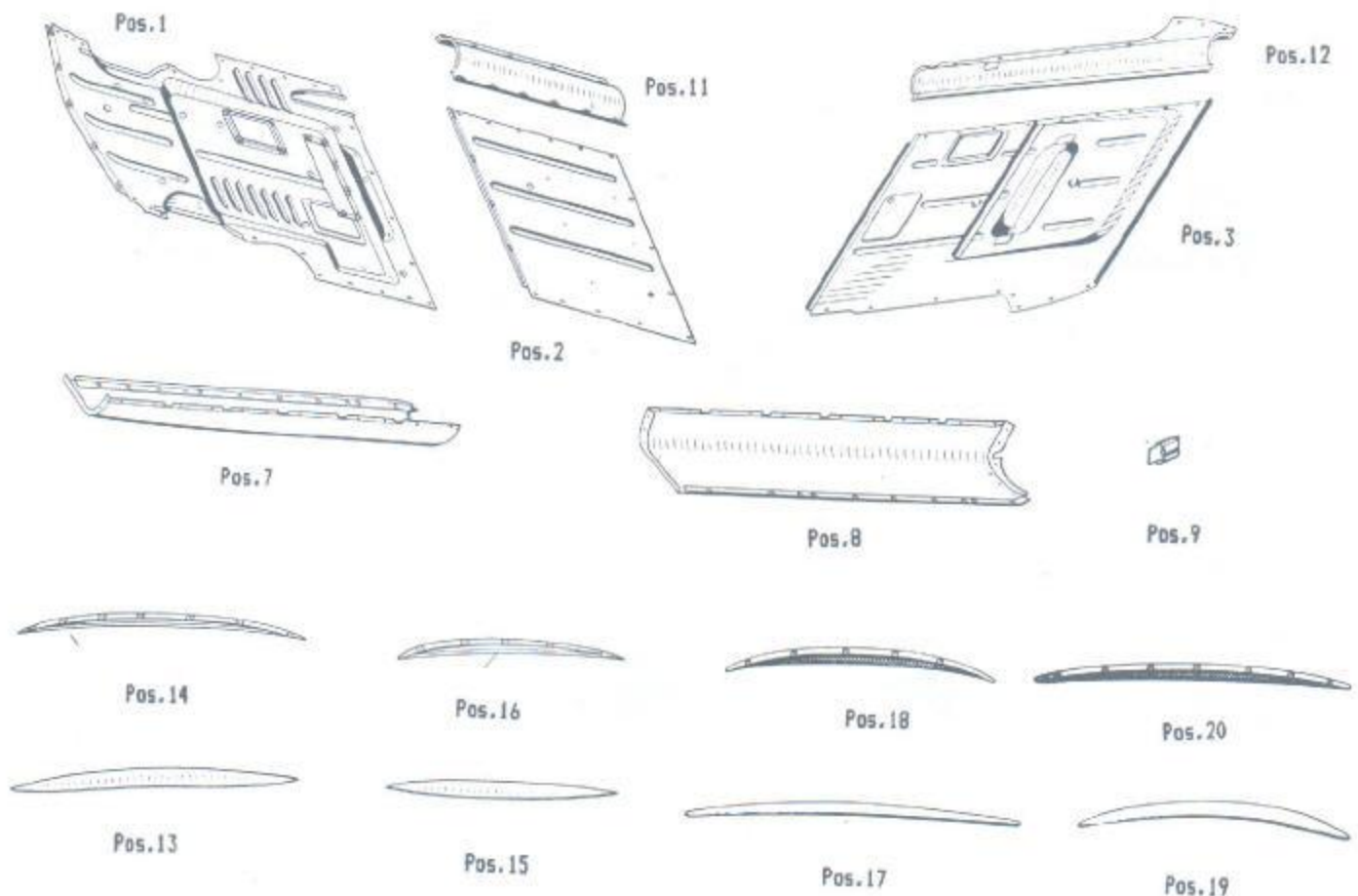

	Typenkunde	D. B. Vergleich.Nr.					LagerNr.
1. Trittblech links	300b,c	10	186	880	03	31	2.88025
2. Trittblech rechts	300b,c	10	186	880	04	31	2.88026
3. Trittblech links	300d	10	189	880	05	31	2.88027
4. Trittblech rechts	300d	10	186	880	06	31	2.88028
5. Schutzk. li. a. Trittb.	300,b,c,d	10	186	880	01	36	2.88029
6. Schutzk. re. a. Trittb.	300,b,c,d	10	186	880	02	36	2.88030
7. Abdichtköder	300,b,c,d		000	987	04	31	2.88031
8. Schutzschiene links	300,b,c	10	186	880	01	38	2.88032
9. Schutzschiene rechts	300,b,c	10	186	880	02	38	2.88033
10. Schutzschiene links	300d	10	186	880	03	38	2.88034
11. Schutzschiene rechts	300d	10	186	880	04	38	2.88035
12. Stoßfänger vorn	300b	10	186	880	02	70	2.88036
13. Stoßfänger vorn li.	300b,c	10	186	880	03	72	2.88037
14. Stoßfänger vorn re.	300b,c	10	186	880	04	72	2.88038
15. Mittelstück	300,b,c	10	186	880	00	73	2.88039
16. Horn verchromt	300b	10	186	880	01	55	2.88040
17. Horn f. Stoßfänger	300c	10	186	880	03	55	2.88041
18. Stoßfänger vorn	300d	10	189	880	01	70	2.88042
19. Horn	300d	10	189	880	00	55	2.88043
20. Gummiprofil f. Horn	300d		000	987	07	60	2.88044

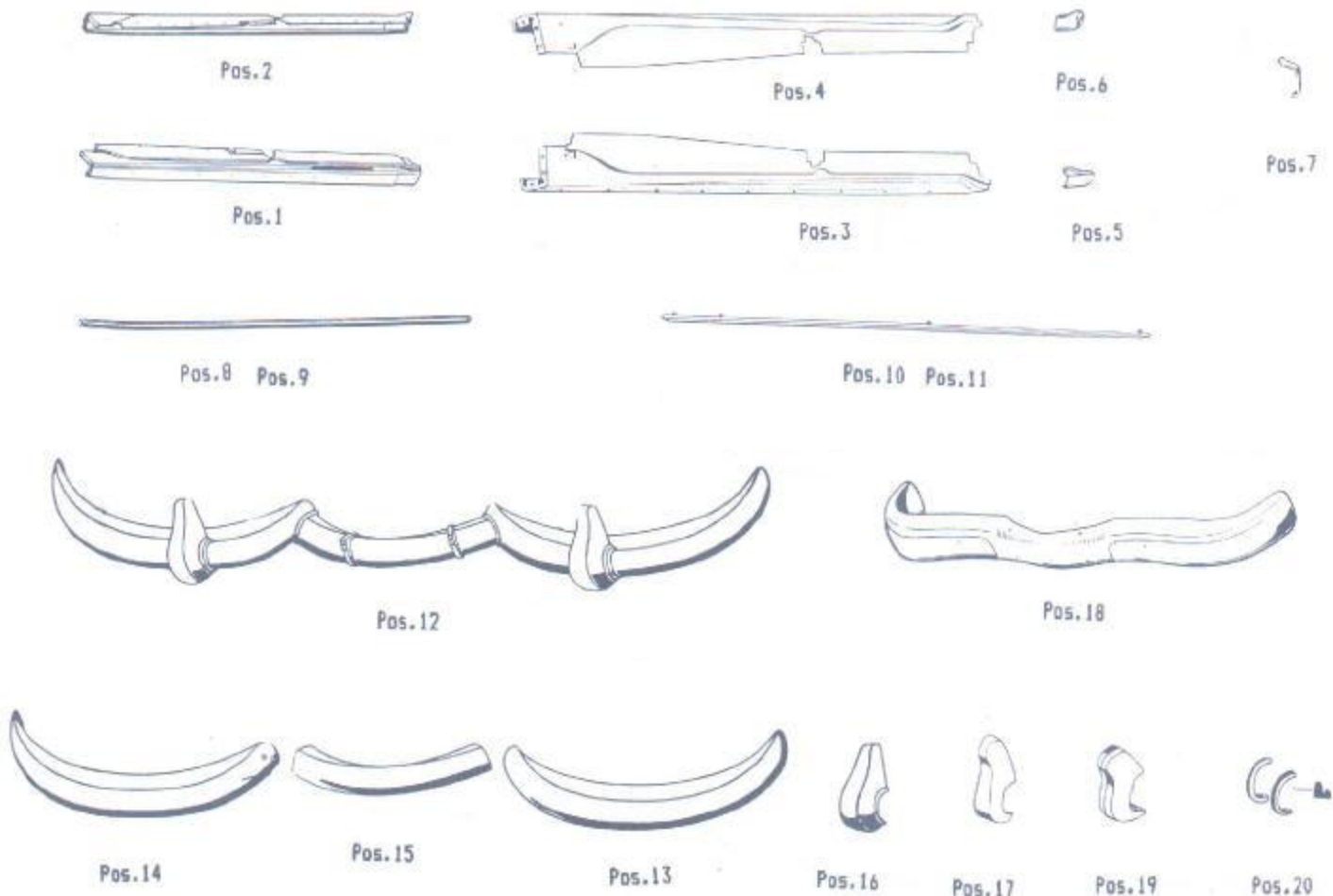



## Typenkunde

## D. B. Vergleich.Nr. LagerNr.

	Typenkunde	D. B. Vergleich.Nr.	LagerNr.
1. Stoßfänger	300S	30 188 880 00 70	2.88045
2. Schutzschiene Mitte	300S	30 188 885 05 74	2.88046
3. Schutzschiene links	300S	30 188 885 06 74	2.88047
4. Schutzschiene rechts	300S	30 188 885 07 74	2.88048
5. Horn links	300S	30 188 880 02 55	2.88049
6. Horn rechts	300S	30 188 880 01 55	2.88050
7. Horn links	300Sc	30 188 880 03 55	2.88051
8. Horn rechts	300S	30 188 880 04 55	2.88052
9. Stoßfänger vorn	300 SL	40 198 880 07 70	2.88053
10. Stoßf. Seitent. li.	300 SL	40 198 880 03 70	2.88054
11. Stoßf. Seitent. re.	300 SL	40 198 880 04 70	2.88055
12. Stoßf. Mittelteil.	300 SL	40 198 880 05 70	2.88056
13. Zierstück links	300 SL	40 198 885 01 16	2.88057
14. Zierstück rechts	300 SL	40 198 885 02 16	2.88058
15. Horn links	300 SL	40 198 880 03 55	2.88059
16. Horn rechts	300 SL	40 198 880 04 55	2.88060
17. Stoßfänger hinten	300b, c	10 186 880 04 71	2.88061
18. Horn links	300b	10 186 880 01 55	2.88062
19. Horn rechts	300c	10 186 880 03 55	2.88063



Pos. 6

Pos. 8



Pos. 12



Pos. 14



Pos. 13



Pos. 15



Pos. 16



Pos. 17



Pos. 18



Pos. 19

	Typenkunde	D.B.	Vergleich.Nr.	LagerNr.
1. Stoßfängerseitenteil links vorn	300 SL Roadster	42 198 880 03 70		2.88064
2. Stoßfängerseitenteil rechts vorn	300 SL Roadster	42 198 880 04 70		2.88065
3. Stoßfängermittelteil	300 SL Roadster	42 198 880 05 70		2.88066
4. Zierstück links	300 SL Roadster	42 198 885 01 16		2.88067
5. Zierstück rechts	300 SL Roadster	42 198 885 02 16		2.88068
6. Horn links	300 SL Roadster	42 198 880 01 55		2.88069
7. Horn rechts	300 SL Roadster	42 198 880 02 55		2.88070
8. Stoßfänger hinten	300d	10 189 880 01 71		2.88071
9. Horn links	300d	10 189 880 01 55		2.88072
10. Horn rechts	300d	10 189 880 03 55		2.88073
11. Stoßfänger hinten	300S	30 188 880 00 71		2.88074
12. Schutzschiene Mitte	300S	30 188 885 02 74		2.88075
13. Schutzschiene links	300S	30 188 885 03 74		2.88076
14. Schutzschiene Mitte	300S	30 188 885 04 74		2.88077
15. Stoßfänger hinten	300Sc	30 188 880 04 71		2.88078
16. Horn links	300S	30 188 880 01 55		2.88079
17. Horn rechts	300S	30 188 880 02 55		2.88080
18. Horn links	300Sc	30 188 880 03 55		2.88081
19. Horn rechts	300Sc	30 188 880 04 55		2.88082

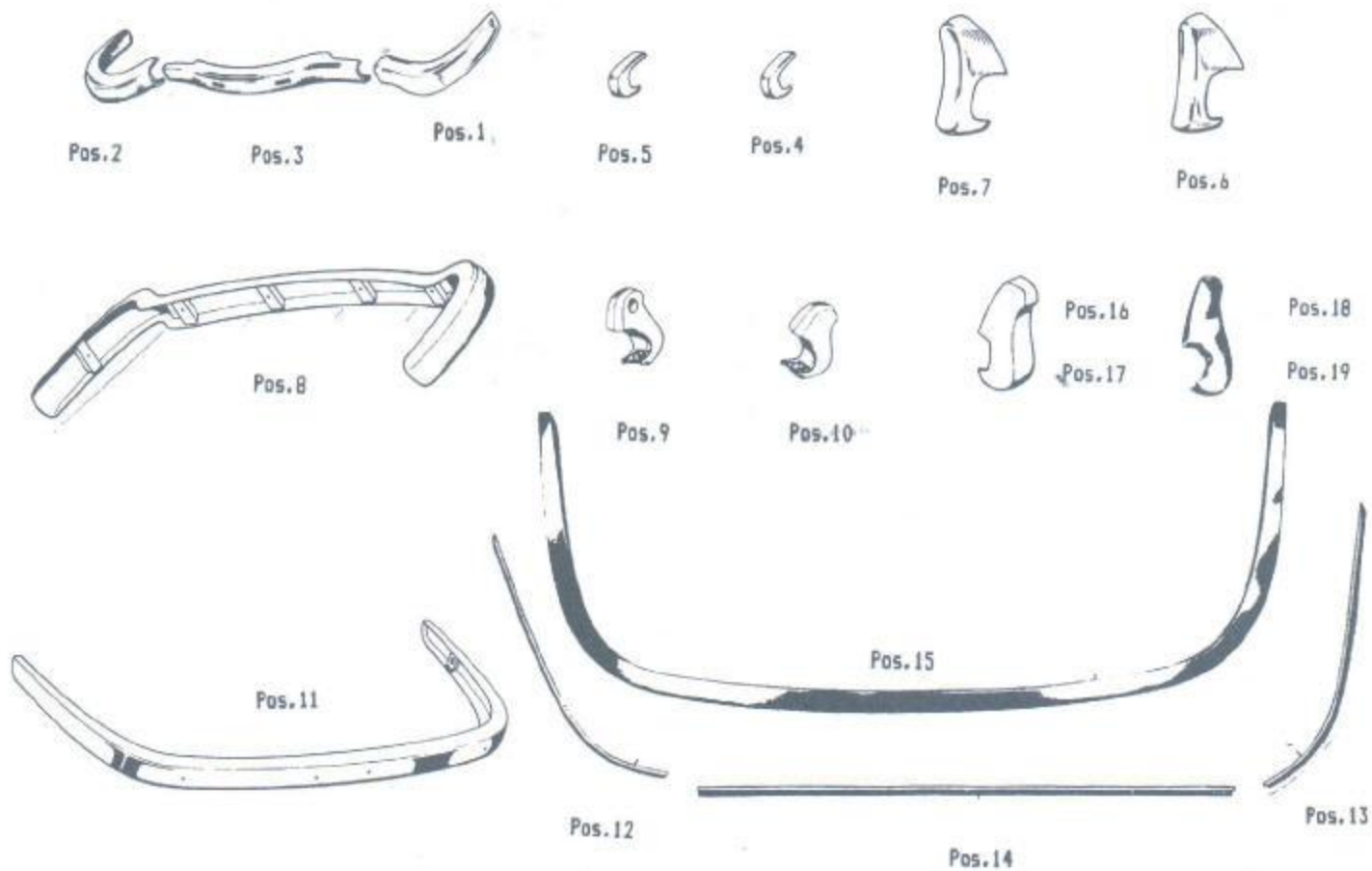



Typenkunde

D. B. Vergleich.Nr. LagerNr.

1. Stoßfänger hinten	300 SL	40 198 880 00 71	2.88083
2. Stoßf. Seitent. li.	300 SL	40 198 880 03 71	2.88084
3. Stoßf. Seitent. re.	300 SL	40 198 880 02 71	2.88085
4. Horn links	300 SL	40 198 880 01 55	2.88086
5. Horn rechts	300 SL	40 198 880 02 55	2.88087
6. Stoßfänger li. hinten	300 SL Roadster	42 198 880 03 71	2.88088
7. Stoßfänger re. hinten	300 SL Roadster	42 198 880 02 71	2.88089
8. Horn links	300 SL	42 198 880 05 55	2.88090
9. Horn rechts	300 SL	42 198 880 06 55	2.88091
10. Eckschutz Motorh. li.	300b,c	10 186 887 01 92	2.88092
11. Eckschutz rechts	300b,c	10 186 887 02 92	2.88093
12. Eckschutz links	300S,Sc	136 527 02 92	2.88094
13. Eckschutz rechts	300S,Sc	136 527 03 92	2.88095
14. Abdichtung Motorhaube	300 SL, Roadster	42 198 887 00 93	2.88096
15. Abdichtg. über Kühler	300 SL, Roadster	40 198 887 03 93	2.88097
16. Kühlerverkleidung	300b,c	10 186 880 00 84	2.88098
17. Kühlerverkleidung	300d	10 189 880 00 84	2.88099
18. Zierleiste längs	300b,c	10 186 888 00 21	2.88100
19. Zierleiste längs	300d	10 189 888 00 21	2.88101
20. Firmenzeichen a. Küh.	300b,c,d	153 500 00 11	2.88102
21. Mercedes Stern	300,b,c,d	10 189 888 00 09	2.88103



Pos. 4

Pos. 5



Pos. 6



Pos. 7



Pos. 8



Pos. 9



Pos. 10



Pos. 12

Pos. 13



Pos. 14

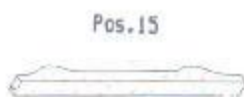

Pos. 15



Pos. 16



Pos. 17



Pos. 18



Pos. 19



Pos. 20



Pos. 21

	Typenkunde	D. B.	Vergleich.Nr.	LagerNr.
1. Kühlerverkleidung	300Sc	30	188 880 02 83	2.88104
2. Zierleiste längs	300S, Sc	30	188 888 00 21	2.88105
3. Mercedes Stern	300S, Sc		312 501 10 16	2.88106
4. Bugverzierung	300 SL	40	198 880 00 23	2.88107
5. Bugverzierung	300 SL Roadster	42	198 880 04 23	2.88108
6. Zierahmen an Bug	300 SL Roadster	42	198 880 07 23	2.88109
7. Zierahmen verchr.	300 SL	40	198 888 00 22	2.88110
8. Zierahmen Oberteil	300 SL Roadster	40	121 888 00 22	2.88111
9. Zierahmen Unterteil	300 SL Roadster	40	121 888 01 22	2.88112
10. Mercedes Stern	300 SL	40	198 880 00 86	2.88113
11. Mercedes Stern	300 SL Roadster	40	198 880 01 86	2.88114
12. Zierstab links in Bugverzierung	300 SL	40	198 880 01 23	2.88115
13. Zierstab rechts	300 SL	40	198 880 02 23	2.88116
14. Zierstab rechts	300 SL Roadster	42	198 880 06 23	2.88117
15. Zierstab links	300 SL Roadster	42	198 880 05 23	2.88118
16. Gitter h. Bugöffnung	300 SL	40	198 880 00 85	2.88119
17. Gitter h. Bugöffnung	300 SL Roadster	42	198 880 00 85	2.88120
18. Karosseriebef. lager vo. 300b,c		10	186 890 00 03	2.89001
19. Gummilager	300b,c	10	186 891 00 01	2.89002
20. Befestigungsplatte	300b,c,d		136 691 07 24	2.89003
21. Werkstatthandbuch	300, b, S, Sc, c			2.99001
22. Werkstatthandbuch	300 SL ,SL Roadster			2.99002

